



Agilent 75000 SERIES B

Agilent E1332A 4-Channel Counter/Totalizer Module

User's Manual



Copyright© Agilent Technologies, Inc., 1995 - 2006



E1332-90003
E0606

Contents

Agilent E1332A 4-Channel Counter/Totalizer Module

Warranty	5
WARNINGS	6
Safety Symbols	6
Declaration of Conformity	7
User Notes	8
Chapter 1. Getting Started with the Agilent E1332A Counter/Totalizer	11
Using This Chapter	11
Counter/Totalizer Description	11
Channel Descriptions and Connections	13
Instrument Definition	14
Programming the Counter/Totalizer	14
Selecting SCPI Commands	14
Chapter 2. Configuring the Agilent E1332A Counter/Totalizer	15
Using This Chapter	15
Warnings and Cautions	15
Setting the Address Switch	16
Selecting the Interrupt Priority	17
Selecting Non-Isolated Input Level	18
Selecting Non-Isolated Input Pull-Up Resistor	18
Connecting Field Wiring	19
Wiring Guidelines	19
Chapter 3. Using the Agilent E1332A Counter/Totalizer	21
Using This Chapter	21
Default Conditions	22
Sequential/Parallel Measurements	23
Input Signal Constraints	24
Input Terminal Selection	24
Totalizing Measurement	25
Gated Totalizing Measurement	27
Up/Down Counting	29
Frequency Measurement	31
Period Average Measurement	34
Pulse Width Measurement	36
Time Interval Measurement	38
Chapter 4. Understanding the Agilent E1332A Counter/Totalizer	41
Using This Chapter	41
Counter/Totalizer Configuration	41
Measurement Procedure	43
Selecting Input Parameters	44
Input Signal Conditioning	44
Event Slope and Event Level	45

Measurement Functions	46
MEASure, CONFigure, and SENSE:FUNCTion	48
INITiate, READ?, and FETCh?	49
Stopping a Measurement	50
Selecting Range and Resolution	50
Range	50
Resolution	50
Setting the Range and Resolution	51
Selecting Aperture Time and Number of Periods	51
Aperture Time (Gate Time)	52
Number of Periods	53
Selecting Gated Totalize	54
Selecting Trigger Source	54
Detecting Errors and Overflows	57
Checking for Errors	57
Checking for Overflow Using Interrupts	58
Checking for Overflow Using an Interrupt	59
Synchronizing Instruments	60
Synchronizing the Counter/Totalizer with a Computer	60
Querying the Counter/Totalizer	61
Chapter 5. Agilent E1332A Counter/Totalizer Command Reference	63
Using This Chapter	63
Command Types	63
Common Command Format	63
SCPI Command Format	63
Linking Commands	66
SCPI Command Reference	66
ABORt	67
CONFigure	68
:FREQuency	69
:NWIDth	70
:PERiod	71
:PWIDth	72
:TINTerval	73
:TOTALize	74
:UDCount	75
CONFigure?	76
DISPlay	77
:MONitor:CHANnel	77
:MONitor:CHANnel?	77
:MONitor[:STATe]	78
:MONitor[:STATe]?	78
FETCh?	79
INITiate	80

INPut	81
:FILTer[:LPASs]:FREQuency	81
:FILTer[:LPASs]:FREQuency?	82
:FILTer[:LPASs][:STATe]	83
:FILTer[:LPASs][:STATe]?	83
:ISOLate	84
:ISOLate?	84
MEASure	85
:FREQuency?	86
:NWIDth?	87
:PERiod?	88
:PWIDth?	89
:TINTerval?	90
READ?	91
[SENSe:]	92
EVENT:LEVel	93
EVENT:LEVel?	93
EVENT:SLOPe	94
EVENT:SLOPe?	94
FREQuency:APERture	95
FREQuency:APERture?	95
FUNction	96
FUNction?	97
PERiod:NPERiods	98
PERiod:NPERiods?	98
TOTalize:GATE	99
:POLarity	99
:POLarity?	99
[:STATe]	100
[:STATe]?	100
STATus	101
:QUEStionable	102
:QUEStionable:CONDition?	102
:QUEStionable:ENABle	102
:QUEStionable:ENABle?	103
:QUEStionable[:EVENT]?	103
SYSTem	104
:ERRor?	104
TRIGger	105
[:IMMediate]	105
:SOURce	105
:SOURce?	106
IEEE 488.2 Common Commands	107
Command Quick Reference	108

Appendix A. Agilent E1332A Specifications	111
Appendix B. Agilent E1332A Register-Based Programming	113
Using This Appendix	113
About Register-Based Programming	113
Addressing the Registers	113
The Base Address	115
Register Offset	116
Register Definitions	116
Register Descriptions	117
Manufacturer ID Register	117
Device Type Register	117
Status (READ)/Control (WRITE) Register	117
Command (WRITE)/Response (READ) Register	119
Parameter Register	120
Interrupt Vector Register	120
Interrupt Requests	121
Command and Parameter Summary	122
Register Command 1	122
Register Command 2	122
Register Command 3	122
Register Command 4	123
Register Command 5	123
Register Command 6	123
Register Command 7	124
Register Command 8	124
Register Command 9	125
Register Command 10	125
Register Command 11	126
Register Command 13	127
Register Command 14	129
Register Command 15	129
Register Programming Procedure	130
Computing the Answer	132
Register Programming Flowchart	134
Embedded Controller Example Programs	135
Register Programmed Pulse Width	141
Appendix C. Agilent E1332A Counter/Totalizer Error Messages	149
Index	151

Certification

Agilent Technologies certifies that this product met its published specifications at the time of shipment from the factory. Agilent Technologies further certifies that its calibration measurements are traceable to the United States National Institute of Standards and Technology (formerly National Bureau of Standards), to the extent allowed by that organization's calibration facility, and to the calibration facilities of other International Standards Organization members.

Warranty

This Agilent Technologies product is warranted against defects in materials and workmanship for a period of one (1) year from date of shipment. Duration and conditions of warranty for this product may be superseded when the product is integrated into (becomes a part of) other Agilent products. During the warranty period, Agilent Technologies will, at its option, either repair or replace products which prove to be defective.

For warranty service or repair, this product must be returned to a service facility designated by Agilent Technologies. Buyer shall prepay shipping charges to Agilent and Agilent shall pay shipping charges to return the product to Buyer. However, Buyer shall pay all shipping charges, duties, and taxes for products returned to Agilent from another country.

Agilent warrants that its software and firmware designated by Agilent for use with a product will execute its programming instructions when properly installed on that product. Agilent does not warrant that the operation of the product, or software, or firmware will be uninterrupted or error free.

Limitation Of Warranty

The foregoing warranty shall not apply to defects resulting from improper or inadequate maintenance by Buyer, Buyer-supplied products or interfacing, unauthorized modification or misuse, operation outside of the environmental specifications for the product, or improper site preparation or maintenance.

The design and implementation of any circuit on this product is the sole responsibility of the Buyer. Agilent does not warrant the Buyer's circuitry or malfunctions of Agilent products that result from the Buyer's circuitry. In addition, Agilent does not warrant any damage that occurs as a result of the Buyer's circuit or any defects that result from Buyer-supplied products.

NO OTHER WARRANTY IS EXPRESSED OR IMPLIED. Agilent SPECIFICALLY DISCLAIMS THE IMPLIED WARRANTIES OF MERCHANTABILITY AND FITNESS FOR A PARTICULAR PURPOSE.

Exclusive Remedies

THE REMEDIES PROVIDED HEREIN ARE BUYER'S SOLE AND EXCLUSIVE REMEDIES. Agilent SHALL NOT BE LIABLE FOR ANY DIRECT, INDIRECT, SPECIAL, INCIDENTAL, OR CONSEQUENTIAL DAMAGES, WHETHER BASED ON CONTRACT, TORT, OR ANY OTHER LEGAL THEORY.

Notice

The information contained in this document is subject to change without notice. Agilent Technologies MAKES NO WARRANTY OF ANY KIND WITH REGARD TO THIS MATERIAL, INCLUDING, BUT NOT LIMITED TO, THE IMPLIED WARRANTIES OF MERCHANTABILITY AND FITNESS FOR A PARTICULAR PURPOSE. Agilent shall not be liable for errors contained herein or for incidental or consequential damages in connection with the furnishing, performance or use of this material. This document contains proprietary information which is protected by copyright. All rights are reserved. No part of this document may be photocopied, reproduced, or translated to another language without the prior written consent of Agilent Technologies, Inc. Agilent assumes no responsibility for the use or reliability of its software on equipment that is not furnished by Agilent.

U.S. Government Restricted Rights

The Software and Documentation have been developed entirely at private expense. They are delivered and licensed as "commercial computer software" as defined in DFARS 252.227- 7013 (Oct 1988), DFARS 252.211-7015 (May 1991) or DFARS 252.227-7014 (Jun 1995), as a "commercial item" as defined in FAR 2.101(a), or as "Restricted computer software" as defined in FAR 52.227-19 (Jun 1987)(or any equivalent agency regulation or contract clause), whichever is applicable. You have only those rights provided for such Software and Documentation by the applicable FAR or DFARS clause or the Agilent standard software agreement for the product involved.

Agilent E1332A 4-Channel Counter/Totalizer Module User's Manual
Edition 4 Rev 2

Copyright © 1995-2006 Agilent Technologies, Inc. All Rights Reserved.

Printing History

The Printing History shown below lists all Editions and Updates of this manual and the printing date(s). The first printing of the manual is Edition 1. The Edition number increments by 1 whenever the manual is revised. Updates, which are issued between Editions, contain replacement pages to correct the current Edition of the manual. Updates are numbered sequentially starting with Update 1. When a new Edition is created, it contains all the Update information for the previous Edition. Each new Edition or Update also includes a revised copy of this printing history page. Many product updates or revisions do not require manual changes and, conversely, manual corrections may be done without accompanying product changes. Therefore, do not expect a one-to-one correspondence between product updates and manual updates.

Edition 1 August 1989
Edition 2 September 1990
Edition 3 December 1992
Edition 4 (Part Number E1332-90003) August 1995
Edition 4 Rev 2 (Part Number E1332-90003) June 2006

Safety Symbols



Instruction manual symbol affixed to product. Indicates that the user must refer to the manual for specific WARNING or CAUTION information to avoid personal injury or damage to the product.



Alternating current (AC).



Direct current (DC).



Indicates hazardous voltages.



Indicates the field wiring terminal that must be connected to earth ground before operating the equipment—protects against electrical shock in case of fault.

WARNING

Calls attention to a procedure, practice, or condition that could cause bodily injury or death.

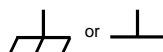

Frame or chassis ground terminal—typically connects to the equipment's metal frame.

CAUTION

Calls attention to a procedure, practice, or condition that could possibly cause damage to equipment or permanent loss of data.

WARNINGS

The following general safety precautions must be observed during all phases of operation, service, and repair of this product. Failure to comply with these precautions or with specific warnings elsewhere in this manual violates safety standards of design, manufacture, and intended use of the product. Agilent Technologies assumes no liability for the customer's failure to comply with these requirements.

Ground the equipment: For Safety Class 1 equipment (equipment having a protective earth terminal), an uninterruptible safety earth ground must be provided from the mains power source to the product input wiring terminals or supplied power cable.

DO NOT operate the product in an explosive atmosphere or in the presence of flammable gases or fumes.

For continued protection against fire, replace the line fuse(s) only with fuse(s) of the same voltage and current rating and type. DO NOT use repaired fuses or short-circuited fuse holders.

Keep away from live circuits: Operating personnel must not remove equipment covers or shields. Procedures involving the removal of covers or shields are for use by service-trained personnel only. Under certain conditions, dangerous voltages may exist even with the equipment switched off. To avoid dangerous electrical shock, DO NOT perform procedures involving cover or shield removal unless you are qualified to do so.

DO NOT operate damaged equipment: Whenever it is possible that the safety protection features built into this product have been impaired, either through physical damage, excessive moisture, or any other reason, REMOVE POWER and do not use the product until safe operation can be verified by service-trained personnel. If necessary, return the product to an Agilent Technologies Sales and Service Office for service and repair to ensure that safety features are maintained.

DO NOT service or adjust alone: Do not attempt internal service or adjustment unless another person, capable of rendering first aid and resuscitation, is present.

DO NOT substitute parts or modify equipment: Because of the danger of introducing additional hazards, do not install substitute parts or perform any unauthorized modification to the product. Return the product to an Agilent Technologies Sales and Service Office for service and repair to ensure that safety features are maintained.



Manufacturer's Name: Agilent Technologies, Incorporated
Manufacturer's Address: 815 – 14th St. SW
Loveland, Colorado 80537
USA

Declares, that the product

Product Name: 2/4 Channel Counter/Totalizer
Model Number: E1332A
Product Options: *This declaration covers all options of the above product(s).*

Conforms with the following European Directives:

The product herewith complies with the requirements of the Low Voltage Directive 73/23/EEC and the EMC Directive 89/336/EEC (including 93/68/EEC) and carries the CE Marking accordingly.

Conforms with the following product standards:

EMC	Standard	Limit
	IEC 61326-1:1997+A1:1998 / EN 61326-1:1997+A1:1998 CISPR 11:1990 / EN 55011:1991 IEC 61000-4-2:1995+A1:1998 / EN 61000-4-2:1995 IEC 61000-4-3:1995 / EN 61000-4-3:1995 IEC 61000-4-4:1995 / EN 61000-4-4:1995 IEC 61000-4-5:1995 / EN 61000-4-5:1995 IEC 61000-4-6:1996 / EN 61000-4-6:1996 IEC 61000-4-11:1994 / EN 61000-4-11:1994	Group 1 Class A 4kV CD, 8kV AD 3 V/m, 80-1000 MHz 0.5kV signal lines, 1kV power lines 0.5 kV line-line, 1 kV line-ground 3V, 0.15-80 MHz 1 cycle, 100% Dips: 30% 10ms; 60% 100ms Interrupt > 95% @5000ms
	Canada: ICES-001:1998 Australia/New Zealand: AS/NZS 2064.1	

The product was tested in a typical configuration with Agilent Technologies test systems.

Safety
IEC 61010-1:1990+A1:1992+A2:1995 / EN 61010-1:1993+A2:1995
Canada: CSA C22.2 No. 1010.1:1992
UL 3111-1: 1994

1 June 2001
Date

Ray Corson
Product Regulations Program Manager

For further information, please contact your local Agilent Technologies sales office, agent or distributor.
Authorized EU-representative: Agilent Technologies Deutschland GmbH, Herrenberger Strabe 130, D 71034 Böblingen, Germany

Notes

Notes

Notes

Chapter 1

Getting Started with the Agilent E1332A Counter/Totalizer

Using This Chapter

This chapter describes the 4-Channel Counter/Totalizer module, and contains information on how to program it using SCPI (Standard Commands for Programmable Instruments) commands. This chapter contains the following sections:

- Counter/Totalizer Description Page 11
- Instrument Definition Page 14
- Programming the Counter/Totalizer Page 14

Counter/Totalizer Description

Refer to Figure 1-1 for the following explanation of the Counter/Totalizer module. The Agilent E1332A is a four-input, low frequency event counter, capable of counting up to 2^{32} (4.3 billion) operator defined events. In addition to event counting (totalize, gated totalize, and up/down count), the Counter/Totalizer is also capable of time related counting (frequency, period, and time interval), with measurements of signals up to 4 MHz.

The four inputs to the Counter/Totalizer are divided in two 2-channel pairs. Channels 1 & 2 form one pair, and channels 3 & 4 form the other. The basic measurement functions of each channel or channel pair are listed in Table 1-1.

Table 1-1. Channel Measurement Functions

Channel 1	Channel 2	Channel 3	Channel 4
Totalize *Gated Totalize *Up/Down count **Frequency **Period *Time Interval	Totalize **Pulse Width	Totalize *Gated Totalize *Up/Down count **Frequency **Period *Time Interval	Totalize **Pulse Width
* Requires a channel pair (1 & 2 or 3 & 4) to perform measurement. ** Other channel in pair is not available for measurement.			

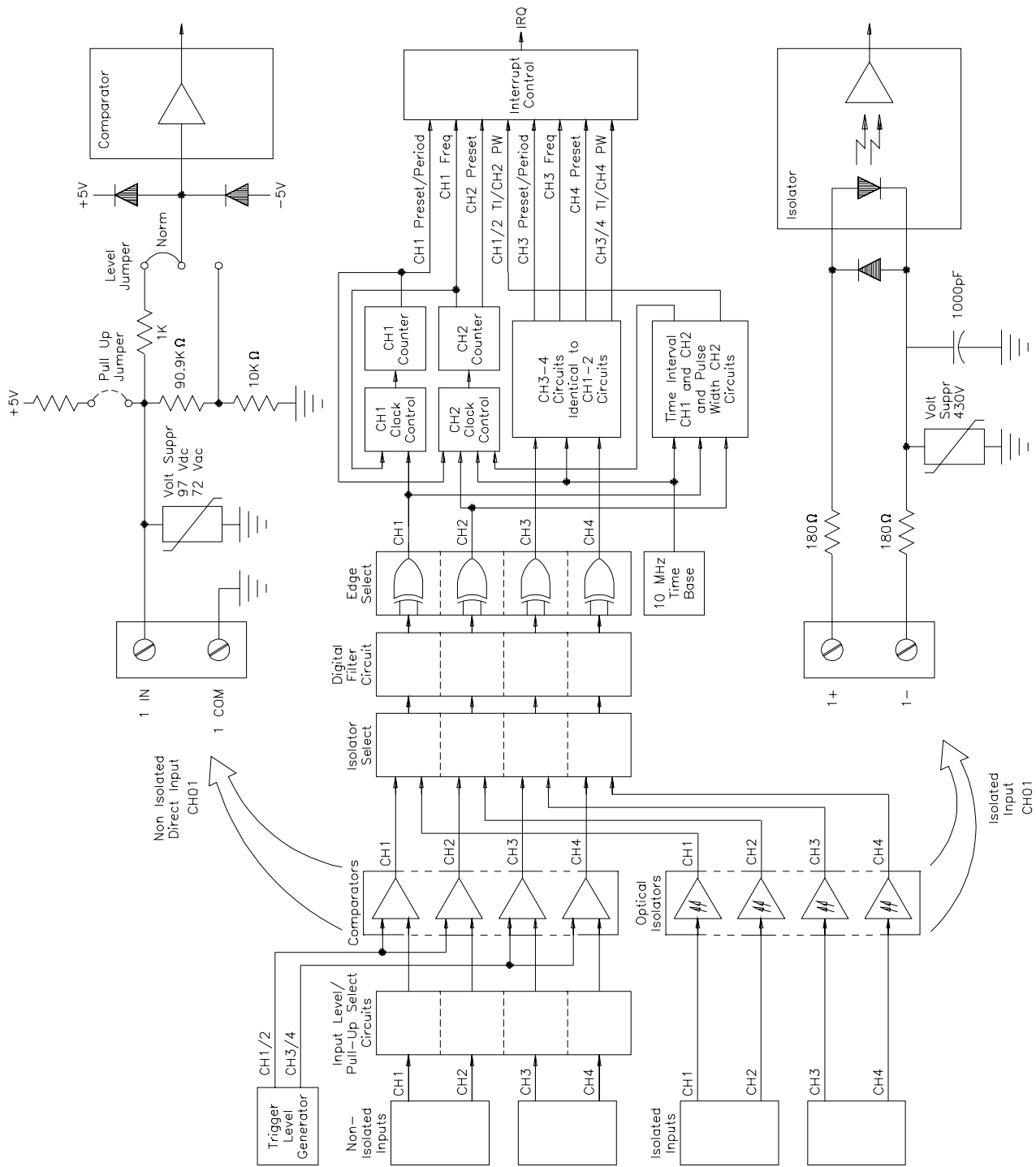

Figure 1-1. Counter/Totalizer Block Diagram

Channel Descriptions and Connections

Each channel has a separate non-isolated (direct) and isolated input terminal. The desired input terminal must be physically connected to the measurement source, and then selected using an appropriate command.

While the measurement functions listed Table 1-1 are identical for non-isolated and isolated inputs, the input characteristics are different. The characteristics for the non-isolated inputs are listed in Table 1-2, and for the isolated inputs are listed in Table 1-3. Complete specifications for the Counter/Totalizer are listed in Appendix A.

Table 1-2. Non-Isolated Input Characteristics

Parameter	Range	Fixed/Selectable
Frequency Range	0.002 Hz to 4 MHz	Fixed.
Input Impedance	100 K Ω	Fixed.
Coupling	DC	Fixed.
Level normal	± 5 V	Each channel independently selectable by jumper on board.
/10	± 42 V	
Event Level normal	-2.56 to +2.54 V	Each channel independently selectable by jumper on board. Each channel pair (1-2, 3-4) selectable in 20 mV steps.
/10	-25.6 to +25.4 V	
Digital LP Filter	4 Hz to 131 kHz	Selectable, and affects all four channels simultaneously.

Caution

DAMAGE LEVEL. Damage to non-isolated input circuits can result if input levels exceed 14 V when normal is selected, or 42 V when /10 is selected.

Table 1-3. Isolated Input Characteristics

Parameter	Range	Fixed/Selectable
Frequency Range	0.002 Hz to 4 MHz	Fixed.
Input High Voltage	>4.2 V	Fixed.
Low Voltage	<1 V	
High Current	>6.3 mA	
Low Current	<250 μ A	
Digital LP Filter	4 Hz to 131 kHz	Selectable, and affects all four channels simultaneously.

Caution **DAMAGE LEVEL.** Damage to isolated input circuits can result if input levels exceed 7 V.

Instrument Definition

Agilent plug-in modules installed in an Agilent mainframe are treated as independent instruments each having a unique secondary GPIB address. Each instrument is also assigned a dedicated error queue, input and output buffers, status registers and, if applicable, dedicated mainframe/command module memory space for readings or data. An instrument may be composed of a single plug-in module (such as a counter) or multiple plug-in modules (for a switchbox or scanning voltmeter Instrument).

Programming the Counter/Totalizer

To program the Agilent E1332A using Standard Commands for Programmable Instruments (SCPI), you must select the controller language, interface address, and SCPI commands to be used. See the *Agilent75000 Series B Installation and Getting Started Guide* for interface addressing and controller language information.

Selecting SCPI Commands

A SCPI command consists of a keyword, such as the INITiate command INIT*n*, where *n* defines the channel. Most keywords require that you specify the channel (1, 2, 3, or 4) you want to act on. If no channel is specified, the default is channel 1. Some keywords must be followed by a number to set a parameter to a specific selection. For example, input filter frequency is "INP:FILT:FREQ 4" where "4" sets the input filter frequency to 4 Hz. Additionally, some keywords must be followed by a value or word to set a parameter to a specific state. For example, input filter on/off is "INP:FILT:STAT ON" or "1". Either the "ON" or "1" enables the input filter.

Chapter 2

Configuring the Agilent E1332A Counter/Totalizer

Using This Chapter

This chapter shows how to connect external wiring to the 4-Channel Counter/Totalizer module inputs, and how to configure the module for measurements. This chapter contains the following sections:

- Warnings and Cautions Page 15
- Setting the Address Switch Page 16
- Selecting the Interrupt Priority Page 17
- Selecting Non-Isolated Input Level Page 18
- Selecting Non-Isolated Input Pull-Up Resistor Page 18
- Connecting Field Wiring Page 19

Warnings and Cautions

Warning **SHOCK HAZARD.** Only service-trained personnel who are aware of the hazards involved should install, remove, or configure the Counter/Totalizer module. Before you remove any installed module, disconnect AC power from the mainframe and from other modules that may be connected to the Counter.

Caution **MAXIMUM VOLTAGE.** The maximum voltage that may be applied to any NON-ISOLATED input connector is 42 V for the /10 jumper position, and 5 V for the normal jumper position. The maximum voltage that may be applied to any ISOLATED input connector is 6.4 at 6.3 mA.

STATIC ELECTRICITY. Static electricity is a major cause of component failure. To prevent damage to the electrical components in the Counter/Totalizer module, observe anti-static techniques whenever removing a module from the mainframe or whenever working on a module.

Setting the Address Switch

The address switch (LADDR) factory setting is 48. You may have changed the setting during module installation. Valid address values are from 0 to 255 (selected value must be a multiple of 8). If the Counter/Totalizer module is used in an Agilent E1300/E1301 Mainframe, refer to the *Agilent 75000 Series B System Installation and Getting Started Guide* for addressing information. Otherwise, use Figure 2-1 to change the setting.

Note The address switch selected value must be a multiple of 8 if the Counter/Totalizer is used in a VXI mainframe.

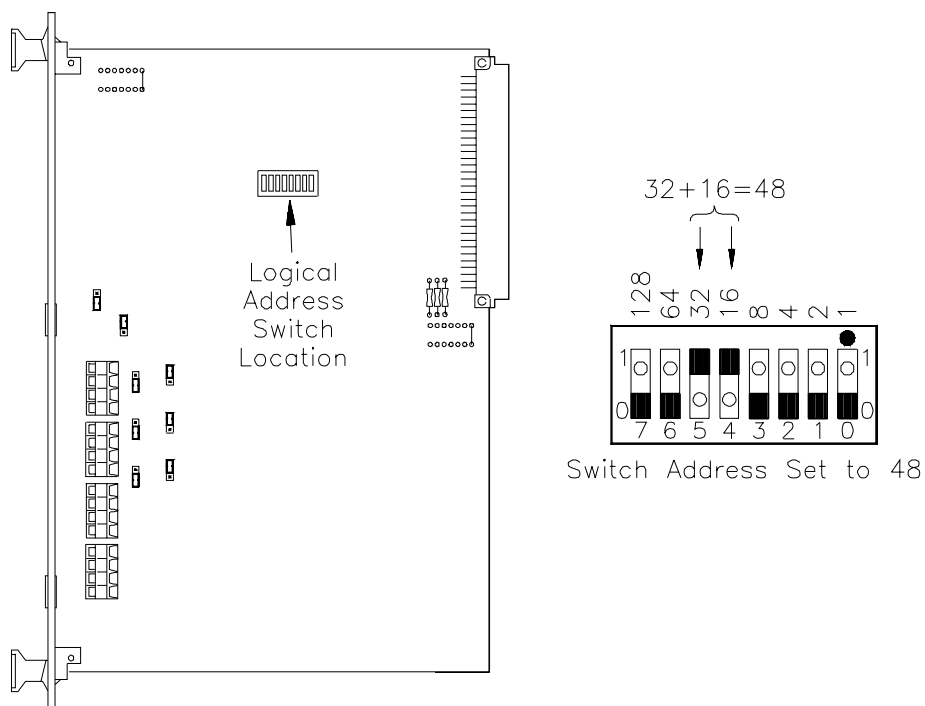

Figure 2-1. Address Selection

Selecting the Interrupt Priority

All Counter/Totalizer functions, except totalize, gated totalize, and up/down counting, generate an interrupt on completion. These interrupts are sent to, and acknowledgements are received from, the slot 0 module via the VXIbus backplane interrupt lines.

The VXI peripheral interrupt bus consists of seven lines which can carry the interrupt signal to the commander. The most common line to be used is line 1, as both the E1300/E1301 Mainframe and E1405/E1406 Command Module manage this line as a default. The E1300/E1301 commander's default is to manage all seven interrupt lines. The E1405/E1406, as a default, manages line one. However, the E1405/E1406 has an interrupt line allocation table which can set which lines will be monitored. When an embedded computer is the commander, check its documentation for how interrupt lines are assigned to it.

When using interrupts during register-based programming, set the counter's interrupt line to a line that is not used by the SCPI driver, which uses line 1. Module interrupt priority can be established with these lines. In general, the higher the line number, the higher the priority.

Refer to Figure 2-2 to change the interrupt priority. You can select seven different interrupt priority levels. Level 1 is the lowest priority and Level 7 is the highest priority. The interrupt priority has a factory setting of Level 1. To change, clip out and remove two jumpers from the old priority location. Install and solder two new jumpers in the new priority location (Figure 2-2 shows a priority change from 1 to 7).

Note Both jumper locations must have the same interrupt priority level jumper (IRQ) installed. Changing the priority level jumpers is not recommended. Do not change unless specifically instructed to do so.

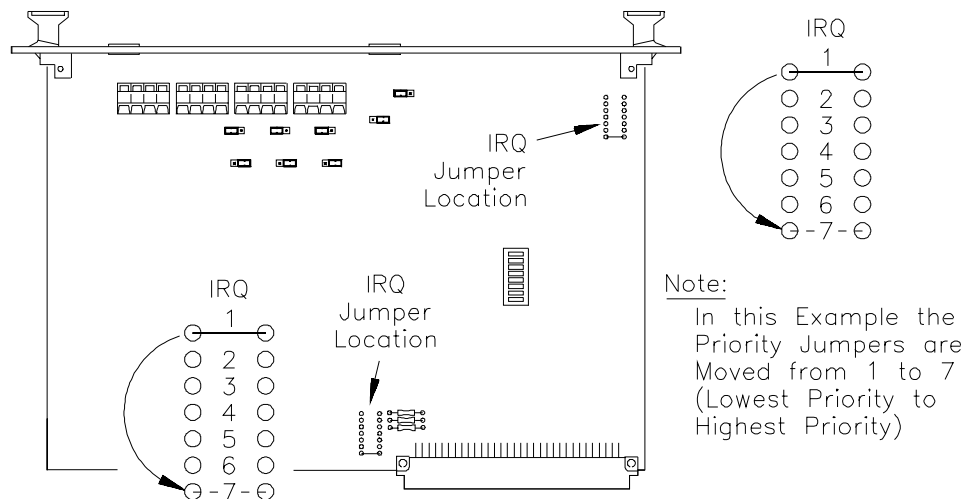

Figure 2-2. Interrupt Priority Selection

Selecting Non-Isolated Input Level

Each of the four Counter/Totalizer non-isolated inputs is capable of providing two different input levels. Each channel has an input selection jumper that provides two values for maximum input level, minimum sensitivity, and maximum event level. Figure 2-3 shows the jumper location for each channel, and the correct position for the desired input level.

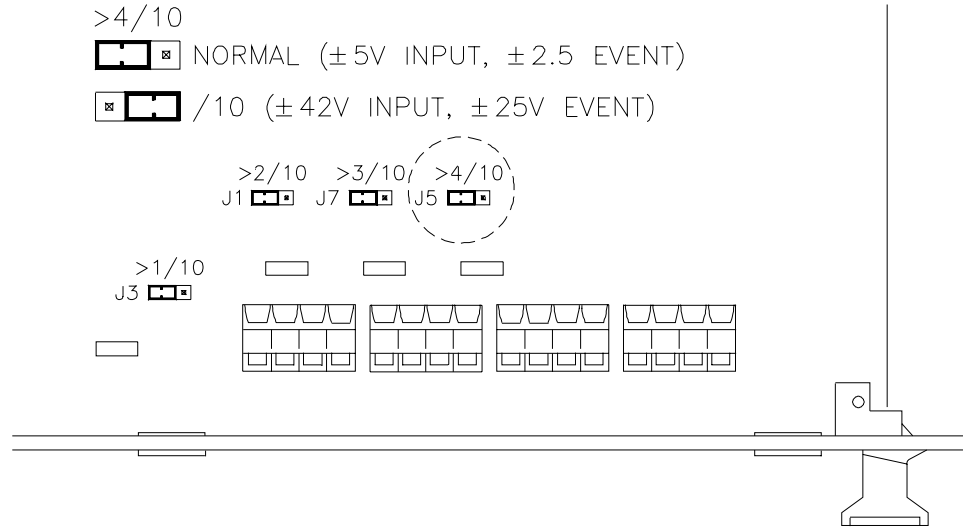

Figure 2-3. Non-Isolated Input Level Selection

Selecting Non-Isolated Input Pull-Up Resistor

Each of the four Counter/Totalizer non-isolated inputs is capable of providing a 4.7 kΩ pull-up resistor connected to +5 V for measuring contact closure (for example, switch closure, dry relay contacts, open collector logic, and so forth). Each channel is provided with an independent selection. Figure 2-4 shows the jumper location for each channel and the correct position for the desired selection.

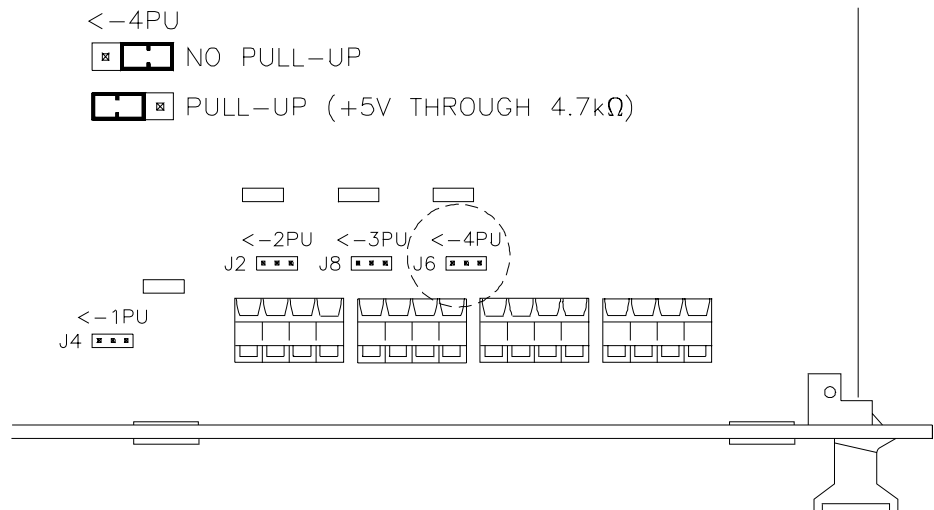

Figure 2-4. Non-Isolated Input Pull-Up Resistor Selection

Connecting Field Wiring

Figure 2-5 shows the input terminal blocks for the Counter/Totalizer isolated and non-isolated inputs. Use the following guidelines for wire connections.

Wiring Guidelines

- If possible, use shielded cables with the shields connected to the common (ground)/low (-) terminals.
- It is recommended that each channel wire be identified (color coded or marked) as the connection is not visible when the Counter/Totalizer module is installed.
- Be sure that wires make good connections on the screw terminals.
- Maximum wire size is No. 16 AWG. Wire ends should be stripped 6 mm (~0.25 inches) and tinned to prevent single strands from shorting adjacent terminals.
- The other end may have any connection the user determines necessary (alligator clips, BNC connector, etc).

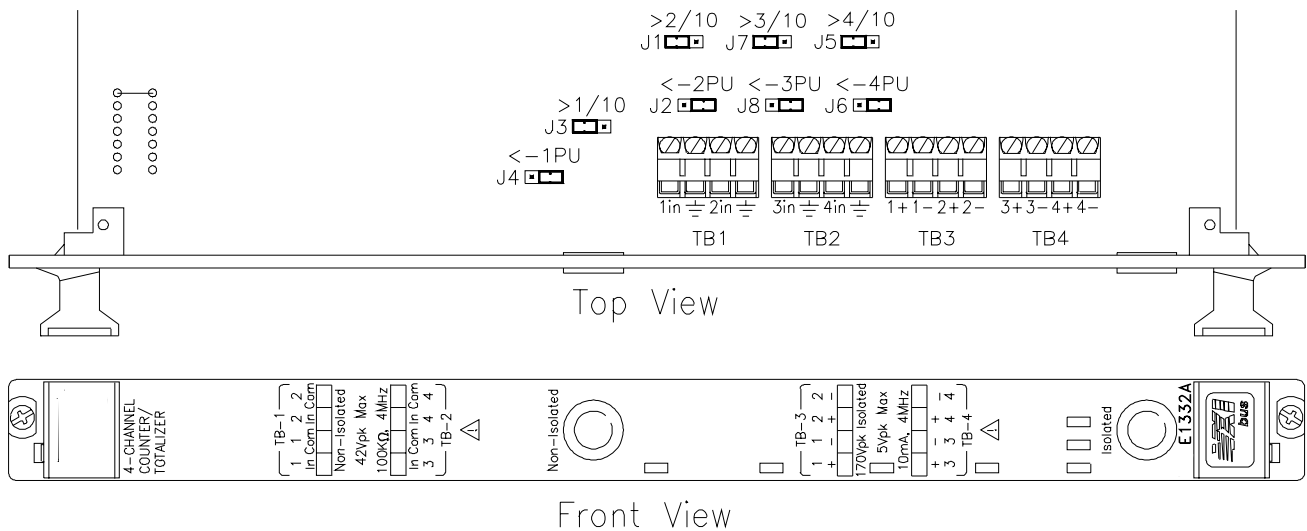

Figure 2-5. Counter/Totalizer Inputs

Chapter 3

Using the Agilent E1332A Counter/Totalizer

Using This Chapter

This chapter uses typical examples to show how to use the 4-Channel Counter/Totalizer. Refer to Chapter 4, “Understanding the Agilent E1332A Counter/Totalizer”, for more information. This chapter contains the following sections:

- Default Conditions Page 22
- Sequential/Parallel Measurements Page 23
- Input Signal Constraints Page 24
- Totalizing Measurement Page 25
- Gated Totalizing Measurement Page 27
- Up/Down Counting Page 29
- Frequency Measurement Page 31
- Period Average Measurement Page 34
- Pulse Width Measurement Page 36
- Time Interval Measurement Page 38

Table 3-1. Counter Commands Used in Chapter 3

Command	Description
*RST	Sets the hardware and software to a known state.
CONF <i>n:xxxx</i>	Configures the Counter/Totalizer to the selected measurement function
INIT <i>n</i>	Initiates the selected measurement and transfers the reading to mainframe/command module memory. Used with CONF.
FETC <i>n?</i>	Transfers the most recent measurement from the mainframe/command module memory to the output buffer. Used with INIT.
MEAS <i>n:xxxx?</i>	Configures the Counter/Totalizer to the selected measurement function, initiates the measurement, and transfers the reading to the output buffer.
SENS <i>n:xxxx</i>	Used to change the selected measurement default parameters, such as event level, slope, etc.
INP: <i>xxxx</i>	Used to change the input default parameters, such as non-isolated to isolate input, digital filter state to on, etc.

n = channel numbers, *xxxx* = measurement function or parameter

Default Conditions

When the Agilent E1332A is switched on or *RST (reset), the input and measurement parameters are set to their default values. Unless these parameters are changed prior to performing the measurement, the default values will be used. Table 3-2 lists the parameters and default values for the measurement functions described in Chapter 3. A reference is provided to the measurement name and its associated example program line number where the default is changed. Chapter 4, “Understanding the Agilent E1332A Counter/Totalizer”, contains the complete list of default parameters.

Table 3-2. Reset (*RST) Default Conditions and Values

Parameter	Default	Example of Changing Default
Input Terminals	Non-Isolated	Period (line 20).
Low Pass Filter State (on/off) Frequency	Off 131.072 kHz	Pulse Width (line 20). Pulse Width (line 30).
Trigger Source	Immediate	Frequency (line 20).
Event Level Slope	0 V Positive	Time Interval (line 40). Time Interval (lines 20 and 30).
Function	FREQ	
Frequency Range Resolution	Auto *5 digits	Frequency (line 30, 1E3). Frequency (line 30, .01).
Period Range Resolution	Auto *5 digits	Period (line 30, 1E-3). Period (line 30, 1E-3).
Gated Totalize State (on/off) Polarity	Off Normal (high)	Gated Totalize (line 30).
* When DEF resolution is selected, measurements will be made to 5 digits of resolution.		

Sequential/Parallel Measurements

All Counter/Totalizer measurements can either be performed sequentially or in parallel.

- **Sequentially:** Measurements are performed one after the other. All example measurements shown in Chapter 3, except frequency measurements, are performed sequentially.
- **Parallel:** Measurements are performed simultaneously. On counting functions (TOT, UDC, gated TOT), no special action is needed to perform simultaneous measurements. For example:

```
CONF1:TOT;;CONF2:TOT;;CONF3:UDC
INIT1;;INIT2;;INIT3
FETC2?
FETC3?
```

For measurements that complete (FREQ, PER, TINT, NWID, PWID), TRIG:SOUR BUS can be used so parallel measurements can be made at the same time. When this technique is used, both measurements start at the same time when the *TRG command or an GPIB Group Execute Trigger (GET) is received. Although each measurement may complete at different times, both results will only become available when the longest measurement completes. See the “Frequency Measurement” section beginning on page 31 for an example.

Input Signal Constraints

Table 3-3 lists the input signal constraints used for Counter/Totalizer measurements. Complete specifications for the Counter/Totalizer are listed in Appendix A.

Table 3-3. Counter/Totalizer Input Signal Constraints

Parameter	Non-isolated Input (Channels 1 to 4)		Isolated Input (Channels 1 to 4)
	Jumper Position		
	Normal	/10	
Maximum frequency	4 MHz	4 MHz	4 MHz
Minimum frequency	0.002 Hz	0.002 Hz	0.002 Hz
Maximum time interval/pulse width	858 sec	858 sec	858 sec
Maximum input	± 5 V	± 42 V	6.4 V @ 6.3 mA
Minimum sensitivity	25 mVrms*	1 Vrms*	N/A
Event Detection			
Maximum Level	± 2.5 V	± 25 V	N/A
Level Step size	20 mV	200 mV	N/A
Isolation	N/A	N/A	170 Vrms **

* at 2 MHz. ** Any channel to chassis, to the data bus, or between any channel pair.

Input Terminal Selection

The Counter/Totalizer is capable of measuring signals on isolated or non-isolated terminals. Use the following guidelines when selecting:

- Non-isolated terminals:** Use non-isolated input terminals whenever high common mode noise is not present. Unlike isolated terminals, allows selection of input level (jumpers), event level, and event slope. All example measurements shown in Chapter 3, except period average, are performed using non-isolated inputs.
- Isolated terminals:** Use isolated input terminals when measuring in high common mode noise environments. Input level can be extended above 6.3 V by use of external dropping resistors. Logic levels that do not provide the necessary >4.2 V at 6.3 mA can be input using a TTL gate to provide the needed drive. See “Period Average Measurement” beginning on page 34 for an example of using non-isolated terminals.

Caution

MAXIMUM VOLTAGE. The maximum voltage that may be applied to any **NON-ISOLATED** input connector is 42 V in the /10 position, and 5 V in the normal position. The maximum voltage that may be applied to any **ISOLATED** input connector is 6.4 V at 6.3 mA.

Totalizing Measurement

The following is a summary of the totalize function.

- Will totalize events on channels 1, 2, 3, and/or 4.
- Maximum reading is 4.29 billion counts (32 bits).
- Reading measurement results will not stop measurement or reset count, allowing for cumulative counts.
- Totalize is a function that does not complete.
- Overflow (>32 bits) information is only updated when the Counter/Totalizer is read with the FETCh? command. See the section titled “Detecting Errors and Overflows” beginning on page 57 for information on overflow indication.

Example: Making a One Channel Non-Isolated Input Totalize Measurement

This example uses the Counter/Totalizer to count the number of times an object interrupts the light from a phototransistor circuit in 10 seconds. The expected input is 0 to 10 V at 600 Hz.

Before programming the measurement, the expected input signal must be analyzed to determine the correct setup. An example is shown below.

- **Input terminals:** Select isolated or non-isolated channels. For the example, non-isolated will be used due to low common mode noise and input signal level (>6.3 V).
- **Level Jumper:** Set to /10 because input level >5 V.
- **Event Level:** Set to input signal midpoint (5 V). Because level jumper is set to /10, a 5 V event level must be entered as 0.5.
- **Event Slope:** Select positive or negative edge sensitivity. For the example, the default value (POSitive) will be used.

Figure 3-1 shows how to connect channel 1 to the signal device. For the example, use:

- an GPIB select code of 7, primary address of 09, and secondary address of 06 for the Counter/Totalizer
- an HP Series 200/300 Computer with BASIC

Execute:

```
10 OUTPUT 70906;"*RST"           !Resets the Counter/Totalizer to its
                                !default state
15 OUTPUT 70906;"SENS1:EVEN:LEV 0.5"!Configures channel 1 and 2
                                !event level to 0.5 V; sets threshold
                                !to midpoint (5 V)
20 OUTPUT 70906;"CONF1:TOT"      !Configures channel 1 for totalize
                                !measurement
30 OUTPUT 70906;"INIT1"         !Starts channel 1 totalize
                                !measurement
40 WAIT 10                       !Allows 10 seconds for
                                !measurement
50 OUTPUT 70906;"FETC1?"        !Transfers channel 1 count to the
                                !output buffer; measurement
                                !continues after transfer
```

60 ENTER 70906;A

!Transfers the measurement from the output buffer to the input buffer of the computer

70 PRINT A

!Displays count on computer

80 END

!Terminates program

Comments **High Noise Environments.** Use ISOLATED terminals when measuring in the presence of high common mode noise. Use the digital low pass input

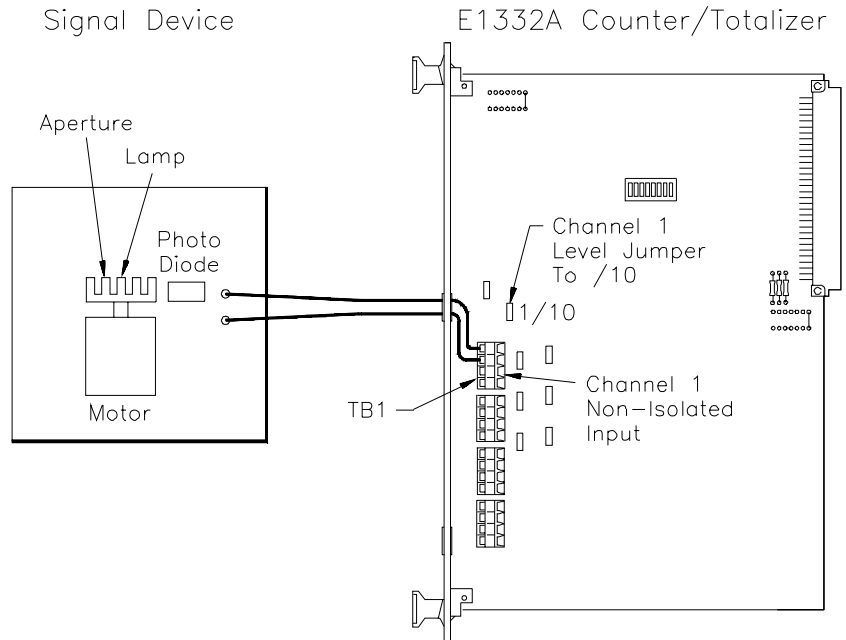

Figure 3-1 Totalizing Measurement (Channel 1)

filter for high normal mode noise.

Timing. When performing totalizing measurements, the Counter/Totalizer must be given sufficient time to configure and initiate the count before the first event is received.

Related SCPI Commands. Commands that directly pertain to Totalize measurements that were not discussed are listed below. Refer to Chapter 5, “Agilent E1332A Counter/Totalizer Command Reference”, for information on these commands.

- **ABORT:** Abort measurement in process.
- **TRIGger:** Select when measurement begins.
- **INPut:** Select digital filter frequency and state, and isolated inputs.

Gated Totalizing Measurement

The following is a summary of the gated totalize function.

- Will totalize gated events on channel pairs 1-2 and/or 3-4.
- Channel 2 gates events on channel 1, and channel 4 gates events on channel 3. Channel 2 or 4 gate polarity can be selected to enable the count when either high or low.
- Maximum reading is 64K counts (16 bits).
- Gated Totalize is a function that does not complete.
- Overflow (>16 bits) information is only updated when the Counter/Totalizer is read with the FETCh? command. See the section titled “Detecting Errors and Overflows” beginning on page 57 for information on overflow indication.

Example: Making a One Channel Non-Isolated Input Gated Totalize Measurement

This example uses the Counter/Totalizer to count the number of clock pulses during the time the gate pulse is high. Both the clock and gate pulse are TTL compatible.

Before programming the measurement, the expected input signals must be analyzed to determine the correct setup. An example is shown below.

- **Input terminals:** Select isolated or non-isolated channels. For the example, non-isolated will be used due to low common mode noise.
- **Level Jumper:** Set both channels to normal because input level ≤ 5 V.
- **Event Level:** Set to detect input signal transition (1.2 V).
- **Event Slope:** Select positive or negative edge sensitivity. For the example, the default value (POSitive) will be used.
- **Gated Channel Polarity:** Select to enable count when normal or inverted. For the example, the default value (NORmal) will be used.

Figure 3-2 shows how to connect channels 1 and 2 to the signal device. For the example, use:

- an GPIB select code of 7, primary address of 09, and secondary address of 06 for the Counter/Totalizer
- an HP Series 200/300 Computer with BASIC

Execute:

```
10 OUTPUT 70906;"*RST"           !Resets the Counter/Totalizer to its
                                !default state
15 OUTPUT 70906;"SENS1:EVEN:LEV 1.2"
                                !Configures channel 1 and 2 event
                                !level to 1.2 V
20 OUTPUT 70906;"CONF1:TOT"      !Configures channel 1 for totalize
                                !measurement
30 OUTPUT 70906;"SENS2:TOT:GATE:STAT ON"
                                !Configures channel 1 and 2 for
                                !gated totalize measurement
40 OUTPUT 70906;"INIT1"         !Initiates measurement
```

```

50 WAIT 10                                !Allows 10 seconds for
                                           measurement
60 OUTPUT 70906;"FETC1?"                  !Transfers channel 1 gated count
                                           to the output buffer; measurement
                                           continues after transfer
70 ENTER 70906;B                           !Transfers the measurement from
                                           the output buffer to the input
                                           buffer of the computer
80 PRINT B                                  !Displays count on computer
90 END                                      !Terminates program

```

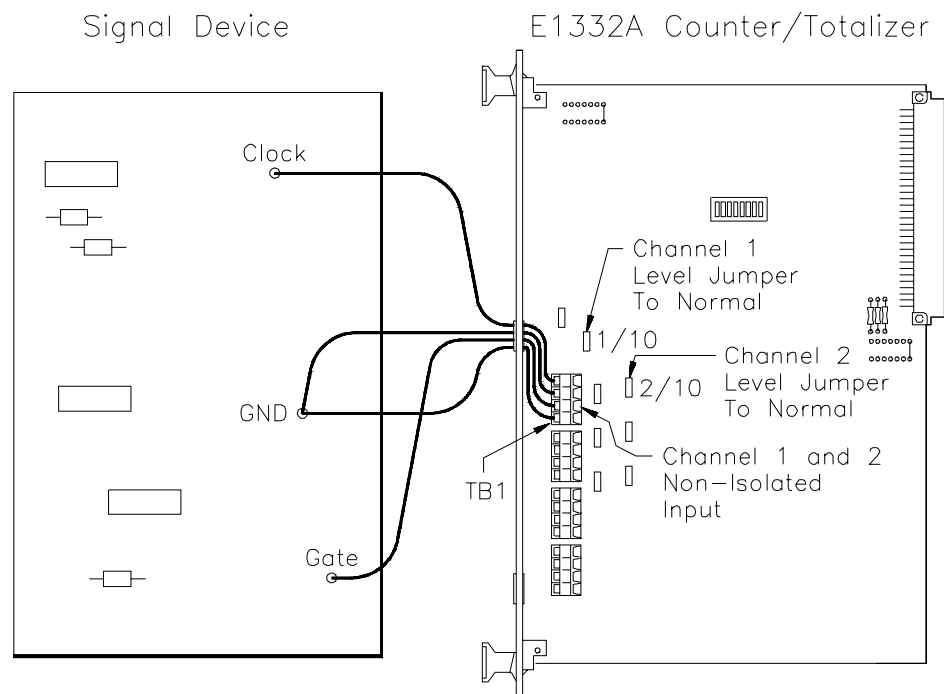

Figure 3-2 Gated Totalizing Measurement (Channel 1-2)

Comments **High Noise Environments.** Use ISOLATED terminals when measuring in the presence of high common mode noise. Use the digital low pass input filter for high normal mode noise.

Signal Connection. When performing gated totalizing measurements, the Counter/Totalizer must be given sufficient time to configure and initiate the count before the first event is received.

Related SCPI Commands. Commands that directly pertain to Gated Totalize measurements that were not discussed are listed below. Refer to Chapter 5, “Agilent E1332A Counter/Totalizer Command Reference”, for information on these commands.

- **ABORt:** Abort measurement in process.
- **TRIGger:** Select when measurement begins.
- **INPut:** Select digital filter frequency and state, and isolated inputs.

Up/Down Counting

The following is a summary of the counting function.

- Counts and calculates the difference between the occurrence of events on channel pairs 1 & 2, and/or 3 & 4.
- Measurement result is total channel 1 count minus total channel 2 count, and/or total channel 3 count minus total channel 4 count.
- Maximum reading is 2.14 billion counts (31 bits).
- Reading results will not stop measurement or reset count, allowing for cumulative counts.
- Up/Down counting is a function that does not complete.

Example: Making a One Channel Non-Isolated Input Up/Down Count Measurement

This example uses the Counter/Totalizer to count the number of pulses generated by a shaft encoder for a period of 100 seconds. When the shaft is rotated clockwise (CW) a pulse is output to channel 3, and when the shaft is rotated counterclockwise (CCW) a pulse is output to channel 4. The difference between CW and CCW rotations of the shaft is measured. Expected input is a TTL level. Before programming the measurement, the expected input signal must be analyzed to determine the correct setup. An example is shown below.

- **Input terminals:** Select isolated or non-isolated channels. For the example, non-isolated will be used due to low common mode noise.
- **Level Jumper:** Set to normal because of input level (≤ 5 V).
- **Event Level:** Set to detect input signal transition (1.2 V).
- **Event Slope:** Select positive or negative edge sensitivity. For the example, the default value (POSitive) will be used.

Figure 3-3 shows how to connect channels 3 and 4 to the signal device. For the example, use:

- an GPIB select code of 7, primary address of 09, and secondary address of 06 for the Counter/Totalizer
- an HP Series 200/300 Computer with BASIC

Execute:

```
10 OUTPUT 70906;"*RST"           !Resets Counter/Totalizer
15 OUTPUT 70906;"SENS3:EVEN:LEV 1.2" !Configures channel 3 and 4 event level to 1.2 V
20 OUTPUT 70906;"CONF3:UDC"       !Configures channel 3 and 4 for up/down counting.
30 OUTPUT 70906;"INIT3"           !Initiates the measurement
40 WAIT 100                       !Allows 100 sec. for measurement
50 OUTPUT 70906;"FETC3?"          !Transfers channel 3 count to output buffer; measurement continues after transfer
60 ENTER 70906;C                  !Transfers the measurement from the output buffer to the input buffer of the computer
```

70 PRINT C

!Displays count on computer. For the example, positive number indicates CW rotation pulses, and a negative number indicates CCW rotation pulses

80 END

!Terminates program

Signal Device

E1332A Counter/Totalizer

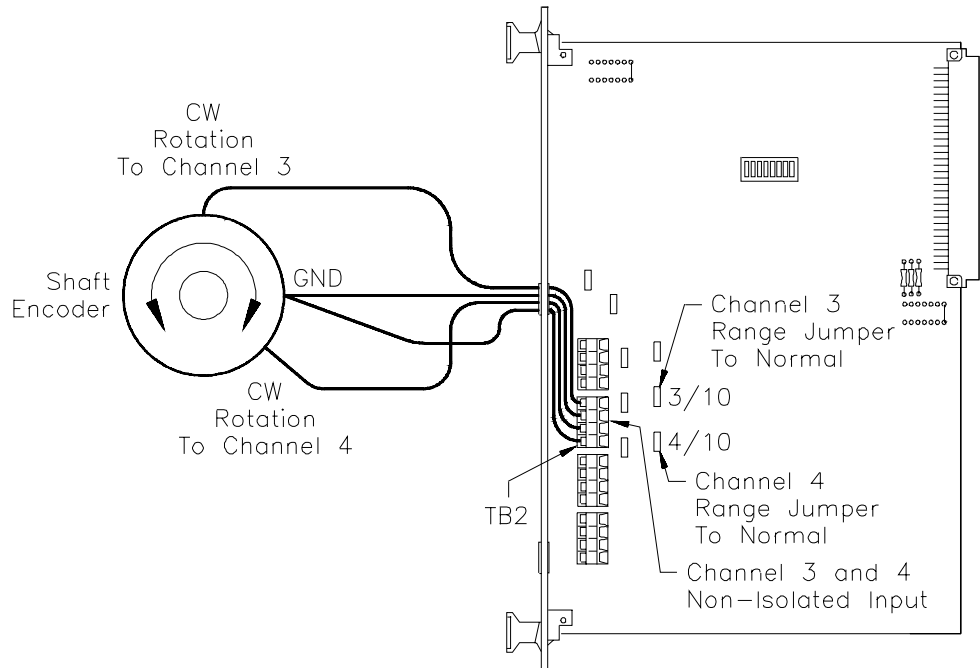

Figure 3-3 Up/Down Counting (Channel 3 and 4)

Comments **High Noise Environments.** Use ISOLATED terminals when measuring in the presence of high common mode noise. Use the digital low pass input filter for high normal mode noise.

Signal Connection. When performing up/down counting, the Counter/Totalizer must be given sufficient time to configure and initiate the count before the first event is received.

Related SCPI Commands. Commands that directly pertain to Up/Down Counting that were not discussed above are listed below. Refer to Chapter 5, “Agilent E1332A Counter/Totalizer Command Reference”, for information on these commands.

- **ABORT:** Abort measurement in process.
- **TRIGger:** Select when measurement begins.
- **INPut:** Select digital filter frequency and state, and isolated inputs.

Frequency Measurement

The following is a summary of the frequency function.

- Frequency can be measured on channel 1 and/or 3.
- Channel 2 cannot be used when channel 1 is measuring frequency, and/or channel 4 cannot be used when channel 3 is measuring frequency.
- Measurement range is 0.002 Hz to 4 MHz.

Example: Making a Two Channel Non-Isolated Input Parallel Frequency Measurement

This example uses the Counter/Totalizer to measure two different frequencies from two different sources. Input one is expected to be a 1 kHz square wave at 2 Vp-p. Input two is expected to be a 1 MHz sinewave at 20 Vp-p. Conditions require both signals to be measured at the same time.

Before programming the measurement, the expected input signals must be analyzed to determine the correct setup. An example is shown below.

- **Input terminals:** Select isolated or non-isolated channels. For the example, non-isolated will be used due to low common mode noise.
- **Level Jumper:** Set one channel to normal (input signal <5 V), and the other channel to /10 (input signal >5 V).
- **Event Level:** Set to input signal mid point (0 V). In the example, event level is not set because 0 V is the default value.
- **Event Slope:** Select positive or negative edge sensitivity. For the example, the default value (POSitive) will be used.

In this example, TRIG:SOUR and *TRG commands will be used to perform both measurements at the same time. Figure 3-4 shows how to connect channel 1 and 3 to the signal device. For the example, use:

- an GPIB select code of 7, primary address of 09, and secondary address of 06 for the Counter/Totalizer
- an HP Series 200/300 Computer with BASIC

Execute:

```
10 OUTPUT 70906;"*RST"           !Resets the Counter/Totalizer
20 OUTPUT 70906;"TRIG:SOUR BUS" !Selects BUS as the trigger source;
                                !measurements will not start until a
                                !trigger command is received
30 OUTPUT 70906;"CONF1:FREQ 1E3,.01;:INIT1"
                                !Configures channel 1 for frequency,
                                !sets the expected frequency to 1 kHz
                                !at a resolution of 0.01 Hz and places
                                !the Counter/Totalizer in the "wait
                                !for trigger" state
40 OUTPUT 70906;"CONF3:FREQ 1E6,10;:INIT3"
                                !Configures channel 3 for frequency,
                                !sets the expected frequency to 1
                                !MHz at a resolution of 10 Hz, and
                                !places the Counter/Totalizer in the
                                !"wait for trigger" state
50 OUTPUT 70906;"*TRG"         !Starts both measurements
```

```

60  OUTPUT 70906;"FETC1?"           !Transfers channel 1 results to
                                     output buffer after readings
                                     complete

70  ENTER 70906;D                   !Transfers the channel 1
                                     measurement from the output
                                     buffer to the input buffer of the
                                     computer

80  OUTPUT 70906;"FETC3?"           !Transfers channel 3 results to the
                                     output buffer

90  ENTER 70906;E                   !Transfers the channel 3
                                     measurement from the output
                                     buffer to the input buffer of the
                                     computer

100 PRINT D,E                       !Displays measurements on
                                     computer

110 END                             !Terminates program and
                                     measurement

```

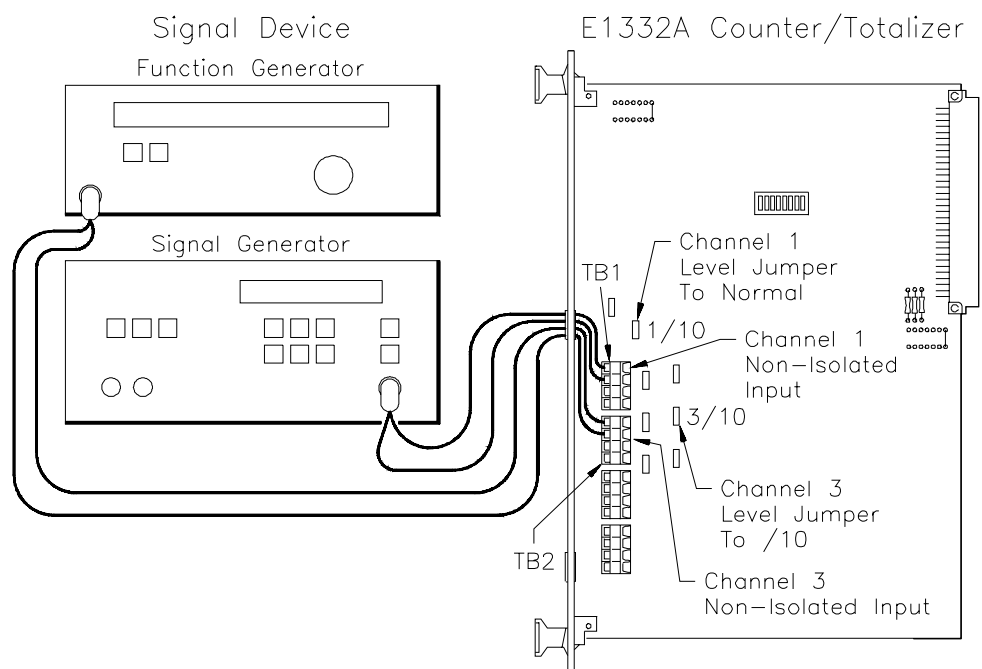

Figure 3-4. Frequency Measurement (Channel 1 and 3)

Comments **High Noise Environments.** Use ISOLATED terminals when measuring in the presence of high common mode noise. Use the digital low pass input filter for high normal mode noise.

Signal Connection. Input signal must be connected to the Counter/Totalizer input before initiating measurement, and remain connected until the measurement is terminated.

Measurement Time. Time needed to complete the measurement is dependent on both the signal input frequency and the resolution specified, and could take a maximum of 858 seconds to complete. If the measurement is performed using default resolution, measurements >1 Hz take <3 sec to complete. See Chapter 4, “Understanding the Agilent E1332A Counter/Totalizer”, for additional information.

Reading Channels 2 and 4. If frequency measurement is in progress, attempting to read Channel 2 or 4 will cause an error.

Related SCPI Commands. Commands that directly pertain to frequency measurements that were not discussed are listed below. Refer to Chapter 5, “Agilent E1332A Counter/Totalizer Command Reference”, for information on these commands.

- **SENSe:** Select aperture time (gate width), and event (trigger) level and slope.
- **INPut:** Select digital filter frequency and state, and isolated inputs.

Period Average Measurement

The following is a summary of the period average function.

- Period average can be measured on channel 1 and/or 3.
- Channel 2 cannot be used when channel 1 is measuring period, and/or channel 4 cannot be used when channel 3 is measuring period.
- Measurement range is 250 nsec to 429 sec.
- See the section titled “Detecting Errors and Overflows” beginning on page 57 for information on overflow indication.

Example: Making a One Channel Isolated Input Period Measurement

This example uses the Counter/Totalizer to measure the period of a test signal. Input is expected to be a 1 kHz TTL compatible clock pulse.

Before programming the measurement, the expected input signal must be analyzed to determine the correct setup. An example is shown below.

- **Input terminals:** Select isolated or non-isolated channels. For the example, isolated will be used due to high common mode noise.
- **Level Jumper:** Not used on isolated inputs.
- **Event Level:** Not used on isolated inputs.
- **Event Slope:** Not used on isolated inputs.

Because TTL signals normally do not supply 4.2 V at 5 mA, a TTL Gate must be used to provide the required drive signal for the isolated input. Figure 3-5 shows how to connect channel 1 to the signal device. For the example, use:

- an GPIB select code of 7, primary address of 09, and secondary address of 06 for the Counter/Totalizer
- an HP Series 200/300 Computer with BASIC

Execute:

```
10 OUTPUT 70906;"*RST"           !Resets the Counter/Totalizer to its
                                   !default state
20 OUTPUT 70906;"INP:ISOL ON"     !Selects isolated terminals for
                                   !measurement
30 OUTPUT 70906;"MEAS1:PER? 1E-3,1E-9"
                                   !Configures channel 1 for period
                                   !measurement, sets the expected
                                   !period to 1 msec at a resolution of
                                   !1 nsec performs the actual
                                   !measurement, then transfers the
                                   !measurement results to the output
                                   !buffer.
40 ENTER 70906;F                 !Transfers the channel 1
                                   !measurement from the output
                                   !buffer to the input buffer of the
                                   !computer
50 PRINT F                       !Displays measurement on
                                   !computer
60 END                           !Terminates program and
                                   !measurement
```

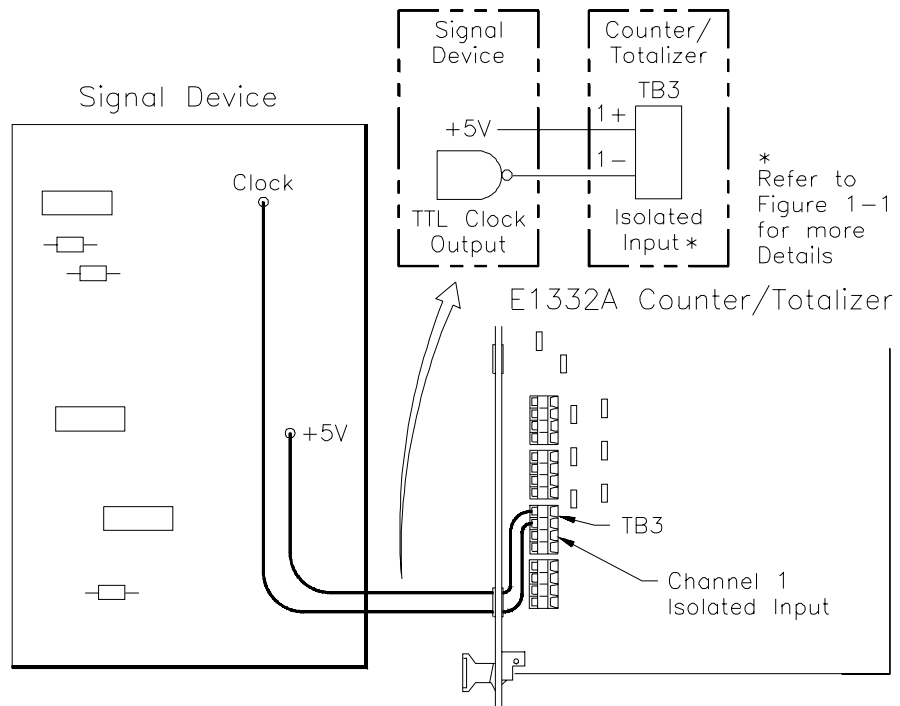

Figure 3-5. Period Measurement (Channel 1)

Comments High Noise Environments. Use ISOLATED terminals when measuring in the presence of high common mode noise. Use the digital low pass input filter for high normal mode noise.

Signal Connection. Input signal must be connected to the Counter/Totalizer input before initiating measurement, and remain connected until the measurement is terminated.

Measurement Time. Time needed to complete the measurement is dependent on both the signal input frequency and the resolution specified, and could take a maximum of 858 seconds to complete. See Chapter 4, “Understanding the Agilent E1332A Counter/Totalizer”, for additional information.

Reading Channels 2 and 4. If period measurement is in progress, attempting to read Channel 2 or 4 will cause an error.

Related SCPI Commands. Commands that directly pertain to Period measurements that were not discussed are listed below. Refer to Chapter 5, “Agilent E1332A Counter/Totalizer Command Reference”, for information on these commands.

- **TRIGger:** Select when measurement begins.
- **SENSe:** Select number of periods to average, and event (trigger) level and slope.
- **INPut:** Select digital filter frequency and state.

Pulse Width Measurement

The following is a summary of the pulse width function.

- Pulse width can be measured on channel 2 and/or 4.
- Channel 1 cannot be used when channel 2 is measuring pulse width, and/or channel 3 cannot be used when channel 4 is measuring pulse width.
- Positive and negative pulse widths can be measured. Positive pulse width is measured from rising to falling edge, and negative pulse width is measured from falling to rising edge.
- Measurement range is 500 nsec to 858 sec.
- See the section titled “Detecting Errors and Overflows” beginning on page 57 for information on overflow indication.

Example: Making a One Channel Non-Isolated Input Pulse Width Measurement With Low Pass Input Filter

This example uses the Counter/Totalizer to measure pulse width of a test signal. Input is expected to be a 50 Hz (20 msec) ECL compatible pulse (1 = -0.89 V, 0 = -1.6 V). A large presence of noise at higher frequencies requires selecting the digital low pass filter at approximately 50 kHz.

Before programming the measurement, the expected input signal must be analyzed to determine the correct setup. An example is shown below.

- **Input terminals:** Select isolated or non-isolated channels. For the example, non-isolated will be used due to low common mode noise and low input signal level (<4.2 V).
- **Level Jumper:** Set to normal because of input level (≤ 5 V).
- **Event Level:** Set to input signal mid point (-1.24 V).
- **Event Slope:** Select positive or negative edge sensitivity. For the example, the default value (POSitive) will be used.

Figure 3-6 shows how to connect channel 4 to the signal device. For the example, use:

- an GPIB select code of 7, primary address of 09, and secondary address of 06 for the Counter/Totalizer
- an HP Series 200/300 Computer with BASIC

Execute:

```
10 OUTPUT 70906;"*RST"           !Resets Counter/Totalizer
15 OUTPUT 70906;"SENS4:EVEN:LEV-1.2"
                                   !Configures channels 3 and 4 event
                                   level to -1.2 V
20 OUTPUT 70906;"INP:FILT:STAT ON"!Enables digital low pass filter
30 OUTPUT 70906;"INP:FILT:FREQ 5E3"!Sets digital low pass filter
                                   frequency to 8.192 kHz
40 OUTPUT 70906;"MEAS4:NWID?"    !Configures channel 4 for negative
                                   pulse width measurement, makes
                                   measurement results to the output
                                   buffer
```

50 ENTER 70906;G

*!Transfers the channel 4
measurement from output buffer to
input buffer of the computer*

60 PRINT G

!Displays measurement

70 END

*!Terminates program and
measurement*

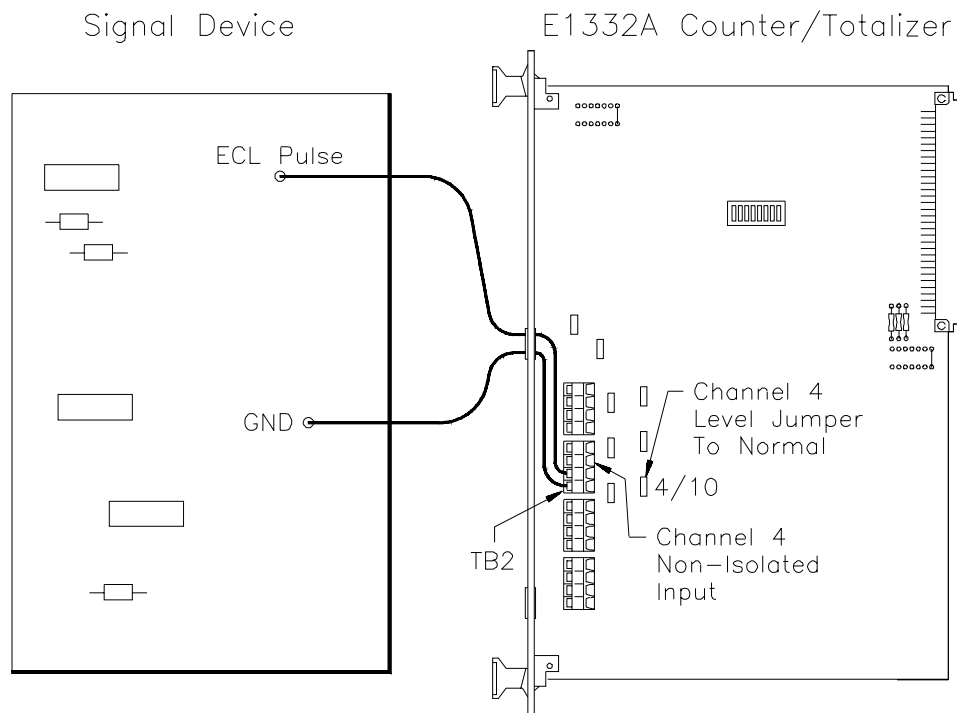

Figure 3-6. Pulse Width Measurement (Channel 4)

Comments **High Noise Environments.** Use ISOLATED terminals when measuring in the presence of high common mode noise. Use the digital low pass input filter for high normal mode noise.

Signal Connection. Input signals must be connected to the Counter/Totalizer input before initiating measurement, and remain connected until the measurement is terminated.

Digital Low Pass Filter. When using the digital low pass filter for pulse width measurements, select the highest possible frequency setting as noise will allow to reduce the possibility of counting errors. In this example, counting error is <0.1%.

Reading Channels 1 and 3. If a pulse width measurement is in progress, attempting to read channel 1 or 3 will cause an error.

Related SCPI Commands. Commands that directly pertain to pulse width measurements that were not discussed are listed below. Refer to Chapter 5, “Agilent E1332A Counter/Totalizer Command Reference”, for information on these commands.

- **TRIGger:** Select when measurement begins.
- **INPut:** Select isolated inputs.

Time Interval Measurement

The following is a summary of the time interval function.

- Time interval of any event can be measured from channel 1 to 2 and/or 3 to 4.
- Can be selected to start and/or stop on rising or falling edge.
- Measurement range is 500 nsec to 858 sec.
- See the section titled “Detecting Errors and Overflows” beginning on page 57 for information on overflow indication.

Example: Making a One Channel Non-Isolated Input Time Interval Measurement with Event Selection

This example uses the Counter/Totalizer to measure the time interval between the falling edges of two pulses. Both inputs are expected to be a TTL compatible.

Before programming the measurement, the expected input signals must be analyzed to determine the correct setup. An example is shown below.

- **Input terminals:** Select isolated or non-isolated channels due to input signal level (<6.3 V). For the example, non-isolated will be used due to low common mode noise.
- **Level Jumper:** Set to normal because of input levels (≤ 5 V).
- **Event Level:** Set to detect input signal transition (1.2 V).
- **Event Slope:** Select negative edge sensitivity on both inputs to measure falling edges.

Figure 3-7 shows how to connect channel 1 and 2 to the signal device. For the example, use:

- an GPIB select code of 7, primary address of 09, and secondary address of 06 for the Counter/Totalizer
- an HP Series 200/300 Computer with BASIC

Execute:

```
10 OUTPUT 70906;"*RST"           !Resets the Counter/Totalizer to its
                                !default state
20 OUTPUT 70906;"SENS1:EVEN:SLOP NEG"
                                !Selects channel 1 event slope to
                                !negative edge
30 OUTPUT 70906;"SENS2:EVEN:SLOP NEG"
                                !Selects channel 2 event slope to
                                !negative edge
40 OUTPUT 70906;"SENS1:EVEN:LEV 1.2"
                                !Selects channel 1 and 2 event
                                !level to +1.2 V
50 OUTPUT 70906;"MEAS1:TINT?"    !Configures channel 1 and 2 for
                                !time interval measurement,
                                !performs the actual measurement,
                                !then transfers the measurement
                                !results to the output buffer
60 ENTER 70906;H                !Transfers the measurement from
                                !the output buffer to the input buffer
                                !of the computer
```

70 PRINT H

*!Displays measurement on
computer*

80 END

*!Terminates program and
measurement*

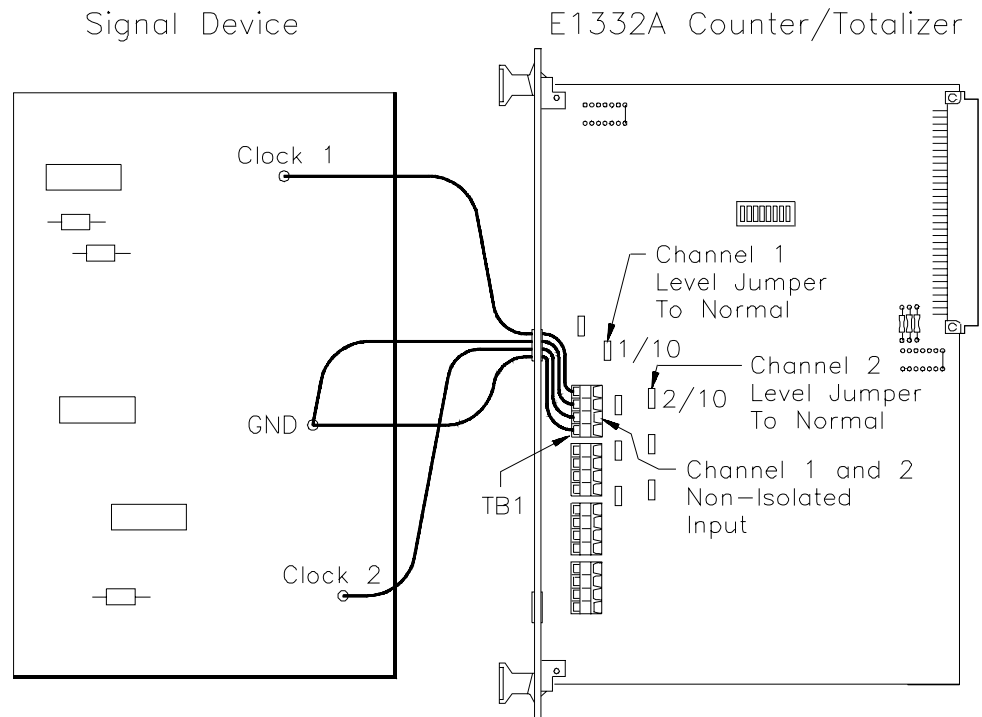

Figure 3-7. Time Interval Measurement (Channel 1-2)

Comments **High Noise Environments.** Use ISOLATED terminals when measuring in the presence of high common mode noise. Use the digital low pass input filter for high normal mode noise.

Signal Connection. Input signal must be connected to the Counter/Totalizer input before initiating measurement, and remain connected until the measurement is terminated.

Digital Low Pass Filter. When using the digital low pass filter for time interval measurements, select the highest possible frequency setting as noise will allow to reduce the possibility of counting errors.

Related SCPI Commands. Commands that directly pertain to time interval measurements that were not discussed above are listed below. Refer to Chapter 5, “Agilent E1332A Counter/Totalizer Command Reference”, for information these commands.

- **TRIGger:** Select when measurement begins.
- **INPut:** Select digital filter frequency and state, and isolated inputs.

Chapter 4

Understanding the Agilent E1332A Counter/Totalizer

Using This Chapter

This chapter shows how to configure the Agilent E1332A 4-Channel Counter/Totalizer when performing measurements. It describes the commands and helps you determine settings to optimize performance. This chapter contains the following sections:

- Counter/Totalizer Configuration Page 41
- Measurement Procedure. Page 43
- Selecting Input Parameters Page 44
- Measurement Functions Page 46
- Selecting Range and Resolution Page 50
- Selecting Aperture Time and Number of Periods Page 51
- Selecting Gated Totalize Page 54
- Selecting Trigger Source Page 54
- Detecting Errors and Overflows Page 57
- Synchronizing Instruments Page 60
- Synchronizing the Counter/Totalizer with a Computer Page 60
- Querying the Counter/Totalizer Page 61

Counter/Totalizer Configuration

The Agilent E1332A performs measurement functions using various SCPI commands to specify measurement conditions and configurations. When the Counter/Totalizer is first turned on or reset (*RST command), the input and measurement parameters are set to their default values. Unless these parameters are changed prior to performing the measurement, the default values will be used. Table 4-1 lists (in alphabetical order) the various commands, along with the default values at turn-on or reset (*RST), and where in Chapter 4 you can find specific programming information.

Note Some commands in Table 4-1 appear in square brackets ([]). These commands are called "implied" commands and are fully explained in Chapter 5. It is important to note that if the implied command is used, the square brackets ([]) are not part of the command and are not sent to the instrument.

Table 4-1. Counter/Totalizer SCPI Commands and *RST (Reset) Default Information

Command	Description	Default	Where to find in Chapter 4
ABOR n :	Abort measurement		Measurement Functions
CONF n :	Configure measurement for:	FREQ	Measurement Functions
TOT	Totalize (and Gated Totalize)		Measurement Functions
UDC	Up/Down count		Measurement Functions
FREQ	Frequency		Measurement Functions
PER	Period		Measurement Functions
PWID	Positive pulse width		Measurement Functions
NWID	Negative pulse width		Measurement Functions
TINT	Time Interval		Measurement Functions
FETC n ?:	Fetch measurement results		Measurement Functions
INIT n [:IMM]	Initiate configured measurement		Measurement Functions
INP:	Input configuration		Selecting Input Parameters
FILT[:LPAS]:FREQ	Digital filter frequency	131.072 kHz	Selecting Input Parameters
FILT[:LPAS][:STATE]	Digital filter state	Off	Selecting Input Parameters
ISOL	Input terminals	Non-Isolated	Selecting Input Parameters
MEAS n :	Perform measurement for:	FREQ	Measurement Functions
FREQ?	Frequency:		Measurement Functions
[<range>[,	Range,	Auto	Selecting Range and Resolution
<resolution>]]	Resolution	5 digits	Selecting Range and Resolution
PER?	Period:		Measurement Functions
[<range>[,	Range,	Auto	Selecting Range and Resolution
<resolution>]]	Resolution	5 digits	Selecting Range and Resolution
PWID?	Positive pulse width		Measurement Functions
NWID?	Negative pulse width		Measurement Functions
TINT?	Time Interval		Measurement Functions
READ?	Perform configured measurement		Measurement Functions
SENS n :			
EVEN:LEV	Event level	0 V	Selecting Input Parameters
EVEN:SLOP	Event Slope	Positive	Selecting Input Parameters
FREQ:APER	Frequency Aperture Time	2 msec*	Selecting Aperture Time and Number Periods
FUNC:	Measurement function for:	FREQ (auto range)	Measurement Functions
TOT	Totalize		Measurement Functions
UDC	Up/Down count		Measurement Functions
FREQ	Frequency		Measurement Functions
PER	Period		Measurement Functions
PWID	Positive pulse width		Measurement Functions
NWID	Negative pulse width		Measurement Functions
TINT	Time Interval		Measurement Functions
PER:NPER	Period Average Number	2 cycles*	Selecting Aperture Time and Number Periods
TOT:GATE:	Gated Totalize measurement		
POL	Polarity	Normal (high)	Selecting Gated Totalize
[STAT]	State	Off	Selecting Gated Totalize
STATus:			
QUESTionable:	Questionable Data/Signal Register		
CONDition?	Condition Register	0	Detecting Error and Overflow Conditions
ENABle	Enable Register	0	Detecting Error and Overflow Conditions
[EVENT]?	Event Register	0	Detecting Error and Overflow Conditions
SYSTem:			
ERRor?	System Errors		Detecting Error and Overflow Conditions
TRIG			
[:IMM]	Trigger Measurement		Selecting Trigger
:SOUR	Trigger Source	Immediate	Selecting Trigger

n = channel number, * FREQ:APER and PER:NPER values are ignored in auto range.

Measurement Procedure

Counter/Totalizer measurements are most successful if the following measurement procedure is followed.

1. Have some understanding of the type of signal you want to measure; its amplitude and frequency; is it periodic and repetitive? An understanding of the signal you want to measure will help you select the correct measurement commands.
2. Set the input parameters (isolated/non-isolated inputs, filter, event level, etc). See “Selecting Input Parameters” on page 44 for more information.
3. Perform the measurement. The measurement may be selected using various commands. See “Measurement Functions” on page 46 for more information. If necessary, modify the measurement selection to meet desired input requirements or optimize measurement speed.
 - Frequency or period measurement range and resolution. See “Selecting Range and Resolution” on page 50.
 - Frequency measurement aperture time. See “Selecting Aperture Time and Number of Periods” on page 51.
 - Period measurement number of periods. See “Selecting Aperture Time and Number of Periods” on page 51.
 - Gated totalize measurements. See “Selecting Gated Totalize” on page 54.
 - Trigger source. See “Selecting Trigger Source” on page 54.

Selecting Input Parameters

Before a measurement can be performed, it is necessary to set up the Counter/Totalizer input and event detecting circuits for the desired input signal. If these values are not changed prior to performing the measurement, the default values listed in Table 4-1 on page 42 will be used. Instructions for selection of the Input Signal Conditioning and Event Slope and Level are provided below.

Input Signal Conditioning

This section discusses the input signal conditioning controls you can program with the INPut command. These controls allow the selection of:

- Input Terminals
- Input Filter State
- Input Filter Frequency

Note

All of the INPut signal conditioning commands affect all channels simultaneously.

Input Terminals

Input can be through non-isolated terminals (direct connection), or isolated terminals (through optical isolator). Refer to Figure 1-1 on page 12 for a detailed diagram of the input circuits. The non-isolated terminals are selected at turn-on or reset. You select input terminals with the following command:

```
INP:ISOL xxx (xxx = ON for isolated, OFF for non-isolated)
```

Input Low-Pass Filter State

The input filter is a digital low-pass filter with a variable cut-off frequency. The filter is disabled at turn-on or reset. You enable the input filter with the following command:

```
INP:FILT[:LPAS][:STAT] <ON | OFF>
```

Input Low-Pass Filter Frequency

The digital input filter cut-off frequency is programmable from 4 Hz to 131.072 kHz in binary steps. When a value is entered that is not a binary step, the next higher binary value will be chosen. For example, if 50 Hz is entered, 64 Hz is used. Selecting a value higher than 131.072 kHz will generate an error. The filter is set to 131.072 kHz at turn-on or reset. You select an input filter frequency with the following command:

```
INP:FILT[:LPAS]:FREQ xxx (xxx = frequency in Hz)
```

Note

When passing signals close to the selected cut-off frequency, a quantizing error can occur. These errors are most noticeable when measuring pulse width and time interval. To minimize the possibility for encountering quantizing errors, choose a cut-off frequency as high as possible for the noise present on the input signal. Refer to Chapter 5 for more information about the INPut:FILT[:LPAS]:FREQuency SCPI command.

Event Slope and Event Level

This section discusses the input event detection controls you can program with the SENSE command. The Counter/Totalizer has event detection controls provided for all channels. These controls allow the selection of event slope and event level.

Note Event slope can be programmed for each channel (1, 2, 3, and 4) independently, while event level can only be programmed for each channel pair (1-2 and 3-4).

Event Slope The POSitive (rising) or NEGative (falling) edge of the input signal can be selected as the sense event for channels 1, 2, 3 and/or 4 independently. POSitive is selected at turn-on or reset. Select event slope with the following command specifying either POS or NEG:

`SENSn:EVEN:SLOP xxx` (n = channel number, xxx = POS or NEG)

Event Level Channel pairs 1-2 and 3-4 can be programmed to an event level between -2.56 V to +2.54 V in 20 mV steps. Selecting a value outside the range will generate an error. 0 V is selected at turn-on or reset. Select event level with the following command:

`SENSn:EVEN:LEV xxx` (n = channel number, xxx = level in volts)

Note When the channel level jumper is in the /10 position, event levels entered as -2.56 V to +2.54 V in 20 mV steps behave as -25.6 V to +25.4 V in 200 mV steps because the input signal is divided by 10. This is referred to as /10.

Measurement Functions

The Counter/Totalizer can make the following measurements as previously described in Chapter 3, “Using the Agilent E1332A Counter/Totalizer”.

- Totalize (TOT) [channels 1, 2, 3, and/or 4]
- Up/Down count (UDC) [channel pairs 1-2, 3-4]
- Frequency (FREQ) [channels 1 or 3]
- Period (PER) [channels 1 or 3]
- Positive pulse width (PWID) [channels 2 or 4]
- Negative pulse width (NWID) [channels 2 or 4]
- Time interval (TINT) [channel pairs 1-2, 3-4]

Depending on the desired measurement, a number of different commands can be used to select and perform the same measurement function. This is because SCPI supports three different "levels" of commands. Use of these different commands to perform the same measurement has two advantages:

- It gives the user a great amount of flexibility in programming.
- It allows the complete use of all the features built into the Counter/Totalizer.

For example, the MEASure and CONFigure commands are signal oriented measurement commands. When using these commands, the Counter/Totalizer will automatically set the necessary instrument parameters to achieve the specified measurement. In addition, the Counter/Totalizer will select the measurement technique (either direct frequency or period) to perform the fastest possible measurement. If the measurement function is frequency and if the period average mode is faster, the actual measurement may be made in the period average mode with the results inverted and returned as a frequency. The SENSE:FUNCTION commands are hardware oriented measurement commands. The Counter/Totalizer's ability to automatically set the necessary instrument parameters and measurement techniques is disabled. Measurements are performed using the techniques specified, and all necessary parameters are under control of the user.

For example, the MEASure, CONFigure, and SENSE:FUNCTION commands will each setup a frequency measurement. The MEASure or CONFigure command will automatically select the aperture time required to obtain 5 digits of resolution, but the SENSE:FUNCTION command requires you to select a specific aperture time.

Figure 4-1 illustrates how the MEASure, CONFigure, and SENSE:FUNCTION commands differ in how they are used with READ?, INITiate, and FETCh? commands, and how they all perform the same measurement and get the data to the output buffer.

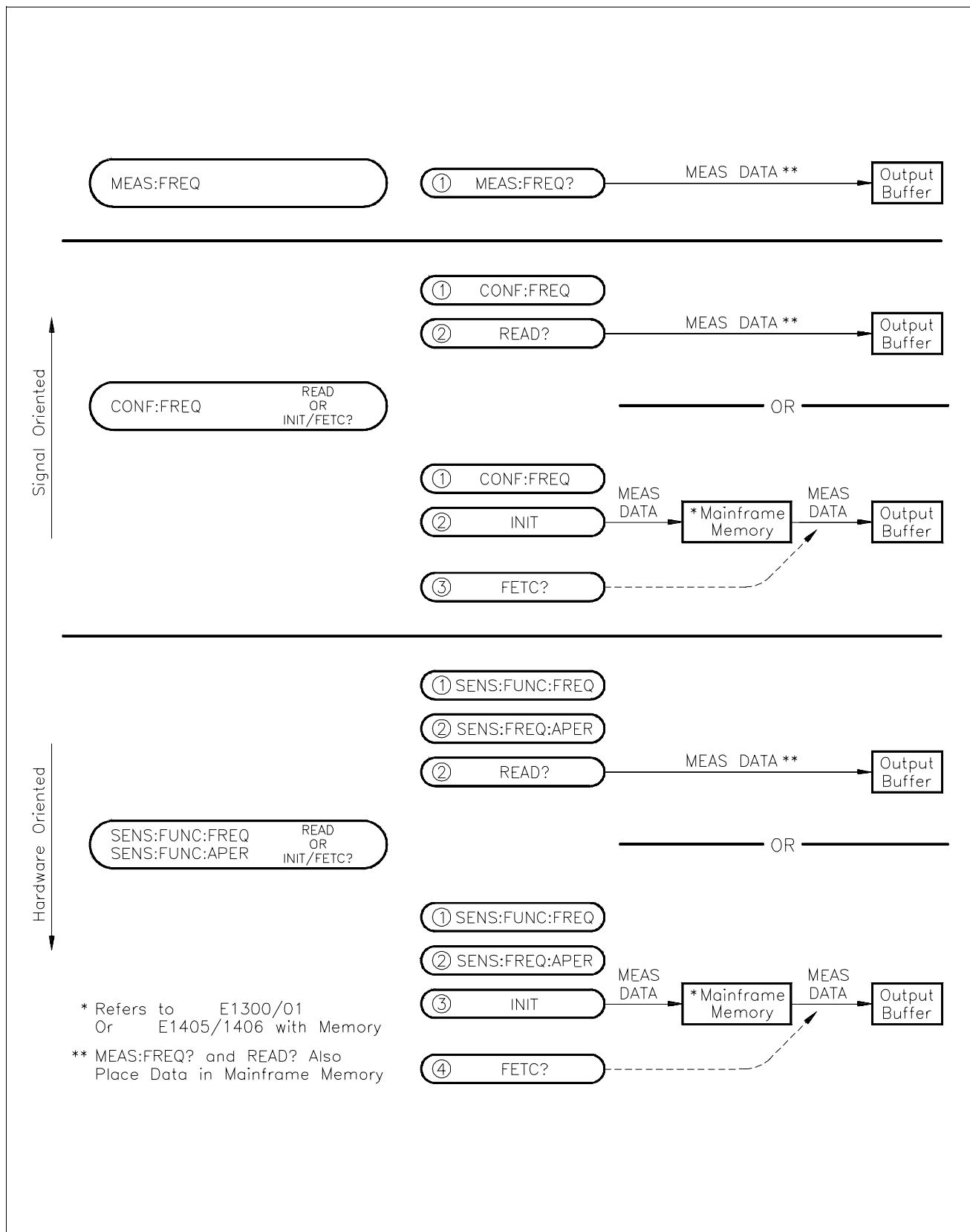

Figure 4-1. Measurement Commands

MEASure, CONFigure, and SENSe:FUNCTion

Only measurements that complete can be performed using the MEASure command. All measurements can be configured with the CONFigure or SENSe:FUNCTion, but at least one additional command must then be used to cause a measurement to be made.

Using MEASure

MEASure is used to make time related measurements. If preceded by a *RST command, the measurement will be performed using the default values listed in Table 4-1 on page 42. MEAS cannot be used on totalize, gated totalize, and up/down count measurements. You select and perform a measurement with the following command:

```
MEASn:function?(n = channel number, function = FREQ, PER, PWID,  
NWID, or TINT)
```

Note

Range and resolution can be entered for frequency and period measurements using the MEASure command. See “Selecting Range and Resolution” on page 50 for more information.

The measurement data obtained is stored in mainframe/command module memory and the output buffer. An enter statement can be used to transfer this data to the computer.

Using CONFigure

CONFigure sets up the configuration, and does not perform the actual measurement. Configure for a measurement with the following command:

```
CONFn:function(n = channel number, function = TOT, FREQ, PER,  
PWID, NWID, TINT or UDC)
```

Once the selected measurement is configured, the measurement is performed using a READ? or INITiate command.

Note

Range and resolution can be entered for frequency and period measurements using the CONFigure command. See “Selecting Range and Resolution” on page 50 for more information.

Using SENSe:FUNCTion

SENSe:FUNCTion only sets up the configuration, and does not perform the actual measurement. Using this command allows the user to specify additional parameters as follows:

- Allows setting of aperture time for frequency measurements. See “Selecting Aperture Time and Number of Periods” on page 51 for information.
- Allows setting the number of periods for period measurements. See “Selecting Aperture Time and Number of Periods” on page 51 for information.

You configure for a measurement with the following command:

```
SENSn:FUNC?:function(n = channel number and function = FREQ,  
NWID, PER, PWID, TINT, TOT or UDC)
```

The selected measurement is configured, and the measurement is performed using an INITiate or READ? command.

Note The SENSE:FUNCTION command need only be used for frequency and period measurements where aperture time or number of periods will be selected. SENSE:FUNCTION:FREQ is a good choice when the input signal may have a frequency of zero. This function always completes. CONF*n*:FREQ or MEAS*n*:FREQ may automatically select the PERiod function which will not complete when the frequency is zero. See “Selecting Aperture Time and Number of Periods” on page 51 for more information.

INITiate, READ?, and FETCh?

After the Counter/Totalizer is configured, the INITiate or READ? command is used to perform the actual measurement.

Using INITiate

INITiate performs the configured measurement and transfers the result to the mainframe/command module memory. The INITiate command is the only way to start totalize, gated totalize, and up/down counting measurements. Perform the configured measurement with the following command:

```
INITn (n = channel number)
```

The selected measurement is performed, and the measurement is stored in mainframe/command module memory. Use the FETCh? command to transfer the result from mainframe/command module memory to the output buffer.

Using READ?

READ? performs the configured measurement and transfers the result to the mainframe/command module memory and to the output buffer. READ? cannot be used on totalize, gated totalize, or up/down count measurements. If a READ? is attempted on an inactive channel (for example, channel 2 during a frequency measurement), an error will be generated. Perform and read a configured measurement with the following command:

```
READn? (n = channel number)
```

The measurement result is then available to be transferred into the computer.

Using FETCh? FETCh? retrieves the most recent measurement from the mainframe/command module memory, and transfers it to the output buffer. For totalize, gated totalize, and up/down count events, the measurement is read directly from the Counter/Totalizer. Therefore, FETCh? must be used with the INITiate command for these measurements. Perform a fetch with the following command:

FETC*n*? (*n* = channel number)

The reading is transferred from mainframe/command module memory to the output buffer. The measurement result is then available to be transferred into the computer.

Stopping a Measurement

The ABORt command stops a measurement in process (trigger idle). Perform an abort with the following command:

ABOR*n* (*n* = channel number)

Note Sending a new measurement command will also abort a measurement in progress.

Selecting Range and Resolution

When using MEASure and CONFIgure to perform frequency and period measurements, it is possible to enter the range or "expected value" of the measurement and the desired resolution. If these values are not specified, AUTO range with 5 digits of resolution is used.

Range

The Counter/Totalizer must sample the input signal long enough to make the measurement to either the default or specified resolution. If range is not specified, the counter operates in the "AUTO" range mode (default mode). When in AUTO, the counter makes a measurement first using the default settings (2 msec for frequency measurements, 2 cycles for period measurements). From this measurement it selects the measurement technique and aperture time or number of periods to perform the measurement to the required resolution. More information about aperture time and number of periods is presented in the section titled "Selecting Aperture Time and Number of Periods" on page 51.

Resolution

Resolution is the smallest change in the measurement that can be discerned. The finer the resolution, the longer the aperture time or number of periods. 5 digits of resolution is selected at turn-on or reset.

Setting the Range and Resolution

You can speed the measurement cycle by specifying the range and resolution of the measurement using the MEASure or CONFigure command. This allows the counter to set the measurement technique and the required aperture time or number of periods for that signal without first making a "sample" measurement.

Note Asking for more resolution generally results in slower measurements.

Use the MEASure or CONFigure commands to specify range and resolution as follows:

MEASn:xxxx? z, y (n = channel number; xxxx = FREQ or PER;
z = expected value in Hz; y = resolution in Hz (or seconds))

CONFn:xxxx z, y (n = channel number; xxxx = FREQ or PER;
z = expected value in Hz; y = resolution in Hz (or seconds))

For example, to set the range to 1 MHz, and resolution to 10 Hz for a frequency measurement on channel 1 using the MEASure command (resulting in a 5 digit measurement), execute:

```
MEAS:FREQ? 1E6, 10
```

Note By specifying the resolution in a MEASure or CONFigure command, the counter automatically selects the proper function (SENSn:FUNC) and the aperture time (SENSn:FREQ:APER) or number of periods (SENSn:PER:NPER required to obtain that resolution. If resolution is specified, range (expected value) must also be specified.

Selecting Aperture Time and Number of Periods

When using SENSE:FUNCTION to perform frequency and period measurements, it is possible to enter the aperture time (for frequency), or the number of periods (for period).

Note By specifying the resolution in a MEASure or CONFigure command, the Counter/Totalizer automatically selects the aperture time or number of periods required to obtain that resolution. The MEASure or CONFigure command also automatically selects either the SENSE:FUNCTION:FREQUENCY or SENSE:FUNCTION:PERIOD function to use. An observation from Table 4-2 and 4-3 is that for signals below 1 MHz, the PERIOD function will probably be used. Explicitly selecting aperture time or number of periods is not required in this case.

Aperture Time (Gate Time)

Aperture time is the period of time the Counter/Totalizer samples the input signal to make a frequency measurement. This period of time directly determines how much resolution you can obtain with a frequency measurement.

Setting the Aperture Time

Aperture time can be specified by using the SENSE command. Setting the aperture time selects a specific resolution.

Aperture time can be set from 2 mS to 65.536 seconds in 16 binary steps. If you specify an aperture time that is not one of the binary steps, the next highest binary step is used. For example, if you specify 10 mS, aperture time is set to 16 mS. 2 mS is selected at turn-on or reset. Table 4-2 shows resolution versus aperture time for the 16 different steps available.

Table 4-2. Resolution versus Aperture Time

Aperture Time in msec	Resolution in Hertz	Min Frequency for 6 digits of Resolution	Min Frequency for 5 digits of Resolution	Min Frequency for 4 digits of Resolution	Min Frequency for 3 digits of Resolution
2	500 Hz				500 kHz
4	250 Hz			2.5 MHz	250 kHz
8	125 Hz			1.25 MHz	125 kHz
16	62.5 Hz			625 kHz	62.5 kHz
32	31.25 Hz		3.1 MHz	313 kHz	31.3 kHz
64	15.625 Hz		1.5 MHz	156 kHz	15.6 kHz
128	7.813 Hz		781 kHz	78.1 kHz	7.81 kHz
256	3.977 Hz	4.0 MHz	398 kHz	39.8 kHz	3.98 kHz
512	1.953 Hz	1.9 MHz	195 kHz	19.5 kHz	1.95 kHz
1024	.977 Hz	977 kHz	98 kHz	9.77 kHz	977 Hz
2048	.488 Hz	488 kHz	40 kHz	4.88 kHz	488 Hz
4096	.244 Hz	244 kHz	24 kHz	2.44 kHz	244 Hz
8192	.122 Hz	122 kHz	12 kHz	1.22 kHz	122 Hz
16384	.061 Hz	61 kHz	6 kHz	610 Hz	61 Hz
32768	.031 Hz	30 kHz	3 kHz	310 Hz	31 Hz
65536	.015 Hz	15 kHz	1.5 kHz	150 Hz	15 Hz

You set aperture time with the command SENSE*n*:FREQ:APER *xxx* (*xxx* = the aperture time in seconds)

Number of Periods

The number of periods is the number of cycles that the Counter samples the input signal to make a period measurement. This period of time directly determines how much resolution you can obtain with a period measurement.

Setting the Number of Periods

The number of periods can be specified by using the SENSE command. Setting the number of periods selects a specific resolution.

Number of periods can be set from 2 to 65,536 cycles in 16 binary steps. If you specify a number of periods that is not one of the binary steps, the next highest binary step is used. For example, if you specify 10, number of periods is set to 16. 2 cycles are selected at turn-on or reset. Table 4-3 shows resolution versus number of periods for the 16 different steps available.

Table 4-3. Resolution versus Number of Periods

Number of Periods to Average	Resolution in Seconds	Max Frequency for 6 digits of Resolution	Max Frequency for 5 digits of Resolution	Max Frequency for 4 digits of Resolution	Max Frequency for 3 digits of Resolution
2	100 nsec	10 Hz	100 Hz	1 kHz	10 kHz
4	50 nsec	20 Hz	200 Hz	2 kHz	20 kHz
8	25 nsec	40 Hz	400 Hz	4 kHz	40 kHz
16	12.5 nsec	80 Hz	800 Hz	8 kHz	80 kHz
32	6.25 nsec	160 Hz	1.6 kHz	16 kHz	160 kHz
64	3.13 nsec	320 Hz	3.2 kHz	32 kHz	320 kHz
128	1.56 nsec	640 Hz	6.4 kHz	64 kHz	640 kHz
256	781 psec	1.28 kHz	12.8 kHz	128 kHz	1.28 MHz
512	390 psec	2.56 kHz	25.6 kHz	256 kHz	2.56 MHz
1024	195 psec	5.12 kHz	51.2 kHz	512 kHz	
2048	97.6 psec	10.24 kHz	102.4 kHz	1.024 MHz	
4096	488.8 psec	20.48 kHz	204.8 kHz	2.048 MHz	
8192	24.4 psec	40.96 kHz	409.6 kHz		
16384	12.2 psec	81.92 kHz	819.2 kHz		
32768	6.10 psec	162.84 kHz	1.63 MHz		
65536	3.05 psec	326.78 kHz	3.27 MHz		

You set number of periods with the command `SENSn:PER:NPER xxx` (*xxx* = the number of periods)

Selecting Gated Totalize

As described in Chapter 3, “Using the Agilent E1332A Counter/Totalizer”, the Counter/Totalizer is capable of making gated totalize measurements. The measurement is performed by using the `SENSe:FUNCTION` or `CONFigure` commands to configure a totalize measurement. The `SENSe` command is then used to enable gated totalize. The commands allow the selection of gated totalize state and gated totalize polarity.

Note Gated totalize requires the measurement to be performed on channel pairs 1-2 and/or 3-4, where channel 2 gates the signal on channel 1, and channel 4 gates the signal on channel 3.

Setting the Gated Totalize State

The gated totalize function is set to off at turn-on or reset. This allows normal totalize measurements to be performed unless the gating is enabled. You enable gating on totalize measurements with the following command:

```
SENSn:TOT:GATE:STAT xxx (n = channel number, xxx = ON or OFF)
```

Setting the Gated Totalize Polarity

The gated totalize measurement can accumulate counts on channel 1 or 3, while the gate (channel 2 or 4) is either high (`NORMAL`) or low (`INVERTED`). The polarity is set to `NORMAL` at turn-on or reset. You select gated totalize polarity with the following command:

```
SENSn:TOT:GATE:POL xxx (n = channel number, xxx = NORM or INV)
```

Selecting Trigger Source

The Counter/Totalizer operates in two states as shown in Figure 4-2.

1. **Idle state.** Configuration of the Counter/Totalizer and its trigger system occur while in the idle state.
2. **Wait-for-trigger state.** When the Counter/Totalizer is ready to make a measurement, it is placed in the wait-for-trigger state.

When the trigger is received from the source specified, the measurement is then made. If the measurement completes (frequency, period, pulse width, and time interval), the Counter/Totalizer returns to the idle state once the measurement completes. If the measurement does not complete (totalize and up/down count), the measurement must be terminated (aborted or reconfigured) before the Counter/Totalizer returns to the idle state.

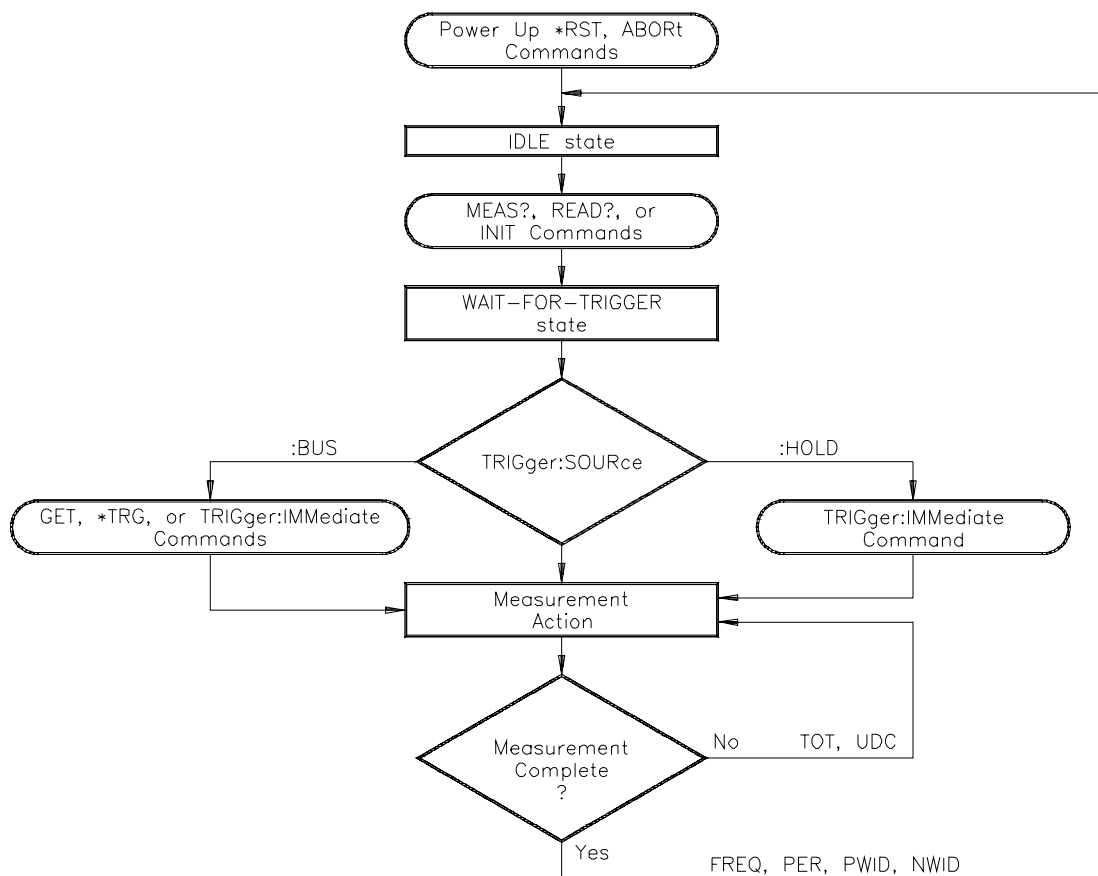

Figure 4-2. Counter/Totalizer Trigger System

Using TRIGger:SOURce

The Counter operates from one of the three trigger sources listed below. These sources are the parameters of the TRIGger:SOURce BUS | HOLD | IMM command. A measurement will not be made until a trigger from the specified source occurs.

- BUS** trigger source is the GPIB Group Execute Trigger (GET) or the system *TRG command. Within the Agilent 75000 Series B mainframe, the instrument whose trigger source is set to BUS and was the last instrument addressed to listen will respond to the GPIB Group Execute Trigger (GET). The system trigger (*TRG) is sent to a specific instrument (for example, OUTPUT 70906;"*TRG").

Note

For measurements that complete (FREQ, PER, TINT, NWID, PWID) TRIG:SOUR BUS can be used so that parallel measurements can be made at the same time. When this technique is used, both measurements start at the same time when the *TRG command or a Group Execute Trigger (GET) is received. Although each measurement may complete at different times, both results will only become available when the longest measurement completes.

- **HOLD** suspends triggering. Once set, the Counter/Totalizer can only be triggered with the TRIGger[:IMMEDIATE] command.
-

Note

Do not confuse the two uses of the word IMMEDIATE in the triggering subsystem. TRIGger[:IMMEDIATE] is used to cause a trigger to occur after the trigger has been disabled (see the TRIGger:SOURce HOLD | BUS commands). TRIGger:SOURce IMMEDIATE effectively bypasses the triggering system so that INITiating a measurement causes it to occur. (see the TRIGger:SOURce IMMEDIATE command).

- **IMMEDIATE** is an internal trigger signal that is always present. Placing the Counter/Totalizer in the wait-for-trigger state (INIT) causes it to be triggered.
-

**Using
TRIGger[:IMMEDIATE]**

Sending the TRIGger[:IMMEDIATE] command causes a trigger cycle to occur immediately. If the trigger has not been disabled (TRIGger:SOURce HOLD | BUS commands) or if the INITiate command has executed, sending the TRIGger[:IMMEDIATE] command will generate an error. A trigger action is performed with the following command:

TRIG:IMM *or* TRIG

Detecting Errors and Overflows

This section discusses using the various Counter/Totalizer registers to detect if a measurement has generated an error or overflow.

Checking for Errors

There are two general approaches to error checking. The simplest, but most time consuming, is to ask the instrument whether there are errors at every step of the measurement process. This is called "polling" and is illustrated in the program segment below.

```
10   OUTPUT 70906;"INP:COUP DC;:SYST:ERR?"
20   ENTER 70906;Err_num
30   IF Err_num <>0 THEN
40       PRINT "Error";Err_num;"occurred"
50       STOP
60   END IF
70   . . . (program continues)
```

The other approach involves the use of interrupts. The following program is a method of checking for errors using interrupts as you program the Counter/Totalizer. The program monitors the Counter/Totalizer's Standard Event Status Register for an error condition. If no errors occur, the Counter/Totalizer functions as programmed. If errors do occur, the Counter/Totalizer interrupts the computer and the error codes and messages are read from the Counter/Totalizer's error queue. This approach requires less overhead but is more complex.

The computer commands shown are for an HP 9000 Series 200/300 computer running BASIC and controlling the Counter/Totalizer over GPIB.

```
10   !Call computer subprogram "Errmsg" if a counter programming error
20   !occurs. Enable the computer to respond to an interrupt from the
25   !counter.
30   !
40   ON INTR 7 CALL Errmsg
50   ENABLE INTR 7;2
60   !
70   !Unmask the Event Status bit in the counter's Status Register. Unmask
80   !the counter error conditions in its Standard Event Status Register.
90   !
100  OUTPUT 70906;"*SRE 32"
110  OUTPUT 70906;"*ESE 60"
120  !
130  !At this point, the counter is programmed for the intended application.
140  !
150  OUTPUT 70906;" ...
160  OUTPUT 70906;" ...
170  !
180  ENTER 70906; ...
190  PRINT ...
200  END
210  !
```

```

220 !When an error occurs, clear the counter to regain control. Execute
230 !a serial poll to clear the service request bit in the Status Register.
240 !Read all error messages in the counter error queue. Clear all
250 !bits in the counter Standard Event Status Register.
260 !
270 SUB Errmsg
280 DIM Message$(256)
290 CLEAR 70906
300 B =SPOLL(70906)
310 REPEAT
320     OUTPUT 70906;"SYS:ERR?"
330     ENTER 70906;Code,Message$
340     PRINT Code,Message$
350 UNTIL Code=0
360 OUTPUT 70906;"*CLS"
370 STOP
380 SUBEND

```

Comments

If you have an Agilent 75000 Series B mainframe with a front panel keyboard, errors can be monitored by selecting "Monitor" from the counter menu. If errors occur when the program executes, the "err" annunciator will appear. Entering SYST:ERR? repeatedly from the keyboard reads all of the messages in the error queue.

The *Agilent 75000 Series B Mainframe User's Manual* contains detailed information on the Status and Standard Event Status registers.

Checking for Overflow Using Interrupts

In the section "Checking for Errors", it is shown that error checking by polling was impractical because of the high overhead. It is also unnecessary since once a program is correct, errors should not occur. For overflow checking, it is practical to poll since overflows are signal dependent and should be checked after a measurement. You only need to check for overflow by polling after a MEAS?, READ?, or FETCh? command. These are the only commands that put the measurement data in the output buffer for entry by the computer. Because of this you have less overhead in polling for an overflow condition. For the example, use:

- an GPIB select code of 7, primary address of 09, and secondary address of 06 for the Counter/Totalizer.
- an HP Series 200/300 Computer with BASIC.

Note

When the counter overflows, it rolls over to zero and keeps on counting.

The following example illustrates overflow checking after a measurement by polling.

```

10     OUTPUT 70906;"MEAS:PER?"
20     !Makes the measurement. Line 60 queries the status questionable
30     !data/signal register to see if the overflow bit was set (a 0 returned
40     !indicates no overflow).

```

```

50    ENTER 70906;Meas_data
60    OUTPUT 70906;"STAT:QUES?"
70    ENTER 70906;Ques_data
80    IF Ques_data 0 THEN
90        PRINT "Overflow occurred"
100   STOP
110   END IF
120   . . . (program continues)

```

Checking for Overflow Using an Interrupt

The following program is a method of checking for overflow conditions using an interrupt. The program monitors bit 3 called QUE in the Counter/Totalizer Status Register for questionable data (see the diagram in the STATUS subsystem command in Chapter 5). The Status Register bit 3 is set true when an overflow occurs. When this bit goes true, the Counter/Totalizer interrupts the computer and the overflow channel is identified by reading the Questionable Data/Signal Register.

The computer commands shown are for an HP 9000 Series 200/300 computer running BASIC and controlling the Counter/Totalizer over GPIB.

```

10    !Call the computer subprogram "Ovrflo" if a counter measurement
20    !overflow occurs. Enable the computer to respond to an interrupt
30    !from the counter.
40    !
50    ON INTR 7 CALL Ovrflo
60    ENABLE INTR 7;2
70    !
80    !Unmask the Questionable Data bit in the counter's Status Register.
90    !Unmask the counter questionable data bits 9, 10, 11, and 12
100   !(channels 1, 2, 3, and 4) in the Questionable Data/Signal Register.
110   !
120   OUTPUT 70906;"*SRE 8"
130   OUTPUT 70906;"STAT:QUES:ENAB 7680"
140   !
150   !Program the counter for the application.
.
.
.
400   !When an overflow occurs, clear the counter to regain control.
410   !Execute a Serial Poll to clear the questionable bit in the Status
420   !Register. Read the Questionable Data/Signal Event Register to
430   !see which channel reported the overflow condition.
440   !
450   SUB Ovrflo
460   Integer=Bitvalue
470   CLEAR 70906
480   B=SPOLL (70906)
490   OUTPUT 70906;"STAT:QUES?"
500   ENTER 70906;Bitvalue
510   PRINT Bitvalue
520   OUTPUT 70906;"*CLS"
530   STOP
540   SUBEND

```

Comments The *Agilent 75000 Series B Mainframe User's Manual* contains detailed information on the Status Byte and Standard Event Status registers for the mainframe.

Synchronizing Instruments

This example shows how you synchronize instruments. In this example, a multiplexer switches a signal to be measured by the Agilent E1332A. This program verifies that the switching is complete before the Counter/Totalizer begins a measurement. For this example, the Counter/Totalizer is at address 70906 and the multiplexer is at 70914.

```
10    !Close channel 101 and request confirmation that the channel is closed.
20    OUTPUT 70914;"CLOSE (@101);*OPC?"
30    !Read confirmation.
40    ENTER 70914;A
50    !At this point the channel is closed and the measurement can be made.
60    OUTPUT 70906;"MEAS:FREQ?"
70    ENTER 70906;Meas_value
80    END
```

Synchronizing the Counter/Totalizer with a Computer

This is an example of how an HP 9000 Series 200/300 computer can monitor the Counter/Totalizer to determine when measurement data is available. The computer can perform other functions while waiting for a Counter/Totalizer measurement. When a measurement completes and data is available, the "Message Available" bit (MAV - bit number 4 in the Status Register) is set true. The computer recognizes this bit set true, stops its current activity, and enters the data.

```
10    !Clear and reset the counter. Unmask the Message Available (MAV)
20    !bit in the Status Register (bit 4).
30    !
40    OUTPUT 70906;"*CLS"
50    OUTPUT 70906;"*RST"
60    OUTPUT 70906;"*SRE 16"
70    !
80    !Configure the counter for a period measurement, make the
90    !measurement, and transfer the data to the output buffer.
100   OUTPUT 70906;"CONF:PER"
110   OUTPUT 70906;"INIT"
120   OUTPUT 70906;"FETC?"
130   !
140   !Monitor the message available bit. Have the computer perform
150   !another function (e.g. display a message) until the bit indicating a
160   !message is available is set. Enter and display the measurement.
170   !
180   WHILE NOT BIT (SPOLL(70906),4)
190       DISP "WAITING FOR DATA"
200       WAIT 1
210       DISP " "
220       WAIT 1
```

```

230  END WHILE
240  ENTER 70906;A
250  PRINT A
260  END

```

Querying the Counter/Totalizer

This section summarizes the query commands you can use to determine the configuration or state of the Counter/Totalizer. Send the command following the item you want to query. All commands end with the “?” which puts the data into the output buffer where your computer can retrieve it.

Aperture time:	SENS n :FREQ:APER? (n = channel number)
Configured measurement:	CONF n ? (n = channel number)
Display monitor channel:	DISP:MON:CHAN?
Display monitor state:	DISP:MON[:STAT]?
Event level:	SENS n :EVEN:LEV? (n = channel number)
Event slope:	SENS n :EVEN:SLOP? (n = channel number)
Function:	SENS n :FUNC? (n = channel number)
Gated totalize polarity:	SENS n :TOT:GATE:POL? (n = channel number)
Gated totalize state:	SENS n :TOT:GATE[:STAT]? (n = channel number)
Input filter state:	INP:FILT[:LPAS][:STAT]?
Input filter frequency:	INP:FILT[:LPAS]:FREQ?
Input terminals (isolated):	INP:ISOL?
Number of periods:	SENS n :PER:NPER? (n = channel number)
Status questionable condition:	STAT:QUES:COND?
Status questionable enable:	STAT:QUES:ENAB?
Status questionable event:	STAT:QUES[:EVEN]?
System error:	SYST:ERR?
Trigger source:	TRIG:SOUR?

Chapter 5

Agilent E1332A Counter/Totalizer Command Reference

Using This Chapter

This chapter describes Standard Commands for Programmable Instruments (SCPI) commands and summarizes IEEE 488.2 Common (*) Commands applicable to the Agilent E1332A 4-Channel Counter/Totalizer. This chapter contains the following sections:

- Command Types Page 63
- SCPI Command Reference Page 66
- IEEE 488.2 Common Commands Page 107
- Command Quick Reference. Page 108

Command Types

Commands are separated into two types: IEEE 488.2 Common Commands and SCPI Commands.

Common Command Format

The IEEE 488.2 standard defines the Common Commands that perform functions like reset, self-test, status byte query, etc. Common commands are four or five characters in length, always begin with the asterisk character (*), and may include one or more parameters. The command keyword is separated from the first parameter by a space character. Some examples of Common Commands are shown below:

*RST *ESR 32 *STB?

SCPI Command Format

The SCPI commands perform functions like selecting input terminals, making measurements, and querying instrument states or retrieving data. A subsystem command structure is a hierarchical structure that usually consists of a top level (or root) command, one or more lower level sub commands, and their parameters. The following example shows a typical subsystem:

```
[ROUTE:]  
  CLOSe <channel_list>  
  SCAN <channel_list>  
    :MODE VOLT
```

[ROUTE:] is the root command, CLOSe and SCAN are second-level commands with parameters, and MODE is a third-level command with the parameter VOLT.

Command Separator A colon (:) always separates one command from the next lower level command as shown below:

ROUTE:SCAN:MODE VOLT

Colons separate the root command from the second-level command (ROUTE:SCAN) and the second-level from the third-level (SCAN:MODE VOLT). The parameters of a command are separated from the command by a blank space.

Abbreviated Commands The command syntax shows most commands as a mixture of upper and lower case letters. The upper case letters indicate the abbreviated spelling for the command. For shorter program lines, send the abbreviated form. For better program readability, you may send the entire command. The instrument will accept either the abbreviated form or the entire command.

For example, if the command syntax shows MEASure, then MEAS and MEASURE are both acceptable forms. Other forms of MEASure, such as MEASU or MEASUR will generate an error. You may use upper or lower case letters. Therefore, MEASURE, measure, and MeAsUrE are all acceptable.

Command keywords can be entered in their full form, as shown above, or can be entered in their short form. In this manual, the entry required in short form commands is always capitalized. The short form is generally used for examples in this manual.

Implied Commands Implied commands are those which appear in square brackets ([]) in the command syntax. (Note that the brackets are not part of the command and are not sent to the instrument.) Suppose you send a second level command but do not send the preceding implied command. In this case, the instrument assumes you intend to use the implied command and it responds as if you had sent it. Examine this excerpt from the [SENSE:] subsystem shown below:

```
[SENSE:]  
  EVENT  
    :LEVel <number | MIN | MAX | DEF>  
    :LEVel?  
    :SLOPe <POSitive | NEGative>  
    :SLOPe?
```

The root command [SENSE:] is an implied command. To set the instrument's trigger level to +1.5, you can send either of the following command statements:

SENS:EVENT:LEV 1.5 *or* EVENT:LEV 1.5

Implied Channel Some commands contain channel numbers in square brackets (for example, [1|2|3|4]). The brackets indicate declaring a channel number in the command is optional. If a channel number is not specified, channel number 1 is implied.

Parameters **Parameter Types.** The following table contains explanations and examples of parameter types you might see later in this chapter.

Parameter Type	Explanations and Examples
Numeric	Accepts all commonly used decimal representations of numbers including optional signs, decimal points, and scientific notation. 123, 123E2, -123, -1.23E2, .123, 1.23E-2, 1.23000E-01. Special cases include MIN, MAX, and DEF. MIN selects minimum value available, MAX selects maximum value available, and DEF selects default or reset value.
Boolean	Represents a single binary condition that is either true or false. 1 or ON; 0 or OFF.
Discrete	Selects from a finite number of values. These parameters use mnemonics to represent each valid setting. An example is the TRIGger:SOURce <source> command where <i>source</i> can be BUS, HOLD, or IMMEDIATE.

Optional Parameters. Parameters shown within square brackets ([]) are optional parameters. (Note that the brackets are not part of the command and are not sent to the instrument.) If you do not specify a value for an optional parameter, the instrument chooses a default value. For example, consider the EVENT:LEVel? [<MIN | MAX | DEF>] command. If you send the command without specifying a parameter, the present EVENT:LEVel value is returned. If you send the MIN parameter, the command returns the minimum count available. If you send the MAX parameter, the command returns the maximum count available. Be sure to place a space between the command and the parameter.

Query Parameters. All selectable numeric parameters can be queried to return the minimum, maximum, or default values they are capable of being set to by sending a MIN, MAX, or DEF optional parameter after the "?". The table below contains all the parameters, along with the values returned.

Parameter Name	MIN	MAX	DEF
DISPlay:MONitor:CHANnel?	1 (channel)	4 (channel)	-1 (AUTO)
INPut:FILTer[:LPASs]:FREQuency?	4 (Hz)	131.072(Hz)	131.072 kHz
[SENSe:]EVENT:LEVel?	-2.56 (V)	+2.54 (V)	0 (V)
[SENSe:]FREQuency:APERture?	2E-3 (sec)	65.536 sec	2E - 3 (sec)
[SENSe:]PERiod:NPERiods?	2 (cycle)	65536(cycle)	2(cycle)

For example, to query the maximum aperture time for frequency measurements, send the following:

```
FREQ:APER? MAX
```

Linking Commands **Linking IEEE 488.2 Common Commands with SCPI Commands.**
Use a semicolon between the commands. For example:

*RST;CONF2:PER *or* TRIG:SOUR HOLD;*TRG

Linking Multiple SCPI Commands. Use both a semicolon and a colon between the commands. For example:

EVEN:LEV 1;;TRIG:SOUR HOLD

SCPI Command Reference

This section describes the Standard Commands for Programmable Instruments (SCPI) commands for the Agilent E1332A 4-Channel Counter/Totalizer. Commands are listed alphabetically by subsystem and alphabetically within each subsystem.

ABORt

The **ABORt** command terminates a measurement by controlling the state of a specific channel's trigger system. Executing the **ABORt** command changes the trigger system from the "wait-for-trigger" state to the "idle" state.

Subsystem Syntax `ABORt[1|2|3|4]`

Parameters Only one channel number can be specified in the command. The channel number defaults to channel 1 if a channel number is not specified.

- Comments**
- **Channel Selection:** Only one channel can be specified at a time.
 - **ABORt and INITiate:** **ABORt** performs the opposite function of the **INITiate** command. **INITiate** starts a measurement, while **ABORt** stops a measurement.
 - **Implied ABORt:** In general, it is not necessary to abort a measurement using the **ABORt** command. Selecting a new function or initiating a new measurement will perform an implied abort.

Example **Aborting a Measurement**

<code>CONF2:PER</code>	<i>Channel 2 function is period.</i>
<code>TRIG:SOUR HOLD</code>	<i>Suspend triggering.</i>
<code>INIT2</code>	<i>Channel 2 go to wait-for-trigger state.</i>
<code>.</code>	
<code>.</code>	
<code>ABOR2</code>	<i>Channel 2 goes to idle state.</i>

CONFigure

The **CONFigure** command subsystem sets up the Counter/Totalizer to perform a specified measurement, either in AUTO range or on a manually entered range, but does not perform the actual measurement. Use the INITiate and FETCh? commands or the READ? commands to initiate the measurement and read the results.

Subsystem Syntax

```
CONFigure[1|2|3|4]
:FREquency [<range>[,<resolution>]]
:NWIDth*
:PERiod [<range>[,<resolution>]]
:PWIDth*
:TINTerval*
:TOTALize*
:UDCounT*
```

Comments

- ***Range and Resolution Ignored:** The optional parameters (*range* and *resolution*) are ignored for NWIDth, PWIDth, TINTerval, TOTALize, and UDCounT measurements.
- **Specifying Range and Resolution:** If the optional parameters are to be used, *range* must be specified if a value for *resolution* is entered. You cannot enter a value for *resolution* without a preceding *range* value.
- **Manual Range:** If the optional parameters *range* and *resolution* are specified, the Counter/Totalizer will set-up and perform the measurement using the values entered. A slightly faster measurement is made when *range* is specified since a sample measurement to determine the correct *range* is unnecessary.
- **Auto Range:** If the optional parameters are not entered, the input signal will be sampled to determine the proper *range* setting, and *resolution* will be set for a default of 5 digits.
- **CONFigure and MEASure versus SENSE:** Most measurements can be performed using one of these three subsystems, and each has advantages and disadvantages over the other. The differences in the commands are:

The CONFigure command can be used for all measurements. The CONFigure command only configures a channel for a specific function, and does not perform the measurement. Use of additional commands (READ? or INIT/FETCh?) to perform the measurement and read the results is necessary. The choice of manual or AUTO ranging for frequency and period functions is provided through the use of optional parameters.

The MEASure command can be used for all measurements except gated totalize, totalize, and up/down count. The MEASure command configures a channel for a specific function, performs the measurement, and returns the results. The choice of manual or AUTO ranging for frequency and period functions is provided through the use of optional parameters.

Both CONFIGure and MEASure commands are instrument independent and can be used in other instruments to perform similar functions. These commands should be used when the portability of instrument syntax is important.

The SENSE subsystem can be used for all measurements. The SENSE:FUNCTION command only configures a channel for a specific function and does not perform the measurement. Use of additional commands (READ? or INIT/FETC?) to perform the measurement and store the results is necessary. Only manual ranging for frequency and period functions is provided, and these parameters may be entered using an additional command (SENS:FREQ:APER or SENS:PER:NPER).

The SENSE commands are instrument dependent and may behave differently in other instruments. These commands should be used when direct control over the measurement is important.

Note SENSE:FUNCTION:FREQ is a good choice when the input signal may have a frequency of zero. This function always completes. CONF n :FREQ or MEAS n :FREQ may automatically select the PERiod function which will not complete when the frequency is zero.

:FREQUENCY CONFIGure[1|3]:FREQUENCY [<range>,<resolution>] configures the Counter/Totalizer for the frequency measurement function. This command does not initiate the measurement process.

Parameters

Parameter Name	Parameter Type	Range of Values	Default Value
<i>range</i>	Numeric	2E-3 to 4E6 Hz MIN MAX AUTO	AUTO
<i>resolution</i>	Numeric	5.4E-13 to 500 Hz MIN MAX	5 digits

Comments

- **Channel Selection:** Select only one channel at a time. The channel number defaults to channel 1 if a channel number is not specified.
- **Acceptable Channels:** Frequency can be measured on channels 1 and/or 3. Depending on the settings, this measurement can continue indefinitely if there is no input signal.
- **Overflow Indication:** Overflow is detected by querying the Questionable Data/Signal Register (see the STATus subsystem later in this chapter).
- **Entering Range:** *Range* can be entered as a number in Hz from 0.002 Hz to 4 MHz. AUTO range is selected when *range* is not

specified. Refer to the section titled “Selecting Range and Resolution” on page 50 for more information.

- **Entering Resolution:** *Resolution* can be entered as a number in Hz from 5.4E-13 Hz to 500 Hz. Entries up to 4E6 are accepted. *Resolution* is automatically set to 5 digits by not entering values for *range* and *resolution*. If *resolution* is entered, *range* must also be entered. Refer to the section titled “Selecting Range and Resolution” on page 50 for more information.

Example **Configuring Frequency Measurements**

CONF3:FREQ 1E6,10

Sets channel 3 function to frequency, range to 1 MHz, and resolution to 10 Hz. Does not perform measurement.

:NWIDth **CONFigure[2|4]:NWIDth** configures the Counter/Totalizer for the negative pulse width measurement function on channel 2 or 4. This command does not initiate the measurement procedure.

Comments

- **Channel Selection:** Select only one channel at a time.
- **Acceptable Channels:** Negative pulse width can be measured on channels 2 and/or 4. The measurement will continue indefinitely until the second edge is detected.
- **Edge Select:** Negative pulse width is measured from the falling edge to the rising edge.
- **Overflow Indication:** Overflow is detected by reading the Questionable Data/Signal Register (see the STATus subsystem later in this chapter).
- **Range and Resolution:** Values for *range* and *resolution* can be entered, but are ignored. Measurement *range* is from 500 nsec to 858 sec, and *resolution* is fixed at 200 nsec.
- **Digital Low-Pass Filter:** To reduce the possibility of counting errors (that reduce the accuracy of the measurement) when using the digital low-pass filter, select the highest filter frequency setting that will eliminate the input noise.

Example **Configuring Negative Pulse Width Measurements**

CONF4:NWID

Sets channel 4 function to negative pulse width. Does not perform measurement.

:PERiod **CONFigure[1|3]:PERiod [*<range>*[,*<resolution>*]]** configures the Counter/Totalizer for the period average measurement function on channel 1 or 3. This command does not initiate the measurement procedure.

Parameters

Parameter Name	Parameter Type	Range of Values	Default Value
<i>range</i>	Numeric	250E-9 to 429 sec MIN MAX AUTO	AUTO
<i>resolution</i>	Numeric	9.6E-16 to .002 sec MIN MAX DEF	5 digits

Comments

- **Channel Selection:** Select only one channel at a time. Channels 2 and 4 cannot make period measurements. The channel number defaults to channel 1 if a channel number is not specified.
- **Acceptable Channels:** Period average can be measured on channels 1 and/or 3.
- **Type of Signal Measured:** Signals must be periodic for the period function.
- **Entering Range:** *Range* is entered as a number in seconds from 250 nsec to 429 seconds. The Counter/Totalizer uses AUTO range when the *range* parameter is not specified. Refer to the section titled “Selecting Range and Resolution” on page 50 for more information.
- **Entering Resolution:** *Resolution* is entered as a number in seconds from 9.6E-16 to .002 seconds. Entries up to 858 seconds will be accepted. *Resolution* is automatically set to 5 digits if *range* and *resolution* are not specified in the command. If *resolution* is entered, it must be preceded by a *range* value. Refer to the section titled “Selecting Range and Resolution” on page 50 for more information.
- **Overflow Indication:** Overflow can be detected by reading the Questionable Data/Signal Register (see the STATus subsystem later in this chapter).

Example **Configuring Period Average Measurements**

CONF3:PER 1E-3,1E-7

Sets channel 3 function to period, range to 1 msec, resolution to 100 nsec. Does not perform measurement.

:PWIDth **CONFigure[2|4]:PWIDth** configures the Counter/Totalizer for the positive pulse width measurement function on channels 2 or 4. This command does not initiate the measurement procedure.

Comments

- **Channel Selection:** Select only one channel at a time.
- **Acceptable Channels:** Positive pulse width can be measured on channels 2 and/or 4. The measurement will continue indefinitely until the second edge is detected.
- **Edge Select:** Positive pulse width is measured from the rising edge to the falling edge.
- **Overflow Indication:** Overflow is detected by reading the Questionable Data/Signal Register (see the STATus subsystem later in this chapter).
- **Range and Resolution:** Values for *range* and *resolution* can be entered, but are ignored. Measurement *range* is from 500 nsec to 858 sec, and *resolution* is fixed at 200 nsec.
- **Digital Low-Pass Filter:** To reduce the possibility of counting errors (that reduce the accuracy of the measurement) when using the digital low-pass filter, select the highest filter frequency setting that will eliminate the input noise.

Example **Configuring Positive Pulse Width Measurements**

CONF2:PWID

Sets channel 2 function to positive pulse width. Does not perform measurement.

:TINterval **CONFigure[1|3]:TINterval** configures the Counter/Totalizer for the time interval measurement function on channels 1 or 3. This command does not initiate the measurement procedure.

Comments

- **Channel Selection:** Select only one channel at a time. The channel number defaults to channel 1 if a channel number is not specified.
- **Acceptable Channels:** Time interval can be measured on channel pairs 1 to 2 and/or 3 to 4. Select channel 1 for 1-2 measurement, and/or channel 3 for 3-4 measurement. Events are measured from channel 1 to channel 2 and/or channel 3 to channel 4. The measurement will continue indefinitely until the second edge is detected.
- **Start and Stop Edges:** The edges of both the start and stop channels can be selected using the **SENSE:SLOPe** command. Unless changed, the measurement will be performed using the presently selected slope.
- **Overflow Indication:** Overflow is detected by reading the Questionable Data/Signal Register (see the **STATus** subsystem later in this chapter).
- **Range and Resolution:** Values for *range* and *resolution* can be entered, but are ignored. Measurement *range* is from 500 nsec to 858 sec, and *resolution* is fixed at 200 nsec. Refer to the section titled “Selecting Range and Resolution” on page 50 for more information.
- **Digital Low-Pass Filter:** To reduce the possibility of counting errors (that reduce the accuracy of the measurement) when using the digital low-pass filter, select the highest filter frequency setting that will eliminate the input noise.

Example **Configuring Time Interval Measurements**

```
CONF3:TINT
```

Sets channels 3 and 4 function to time interval. Does not perform measurement.

:TOTalize **CONFigure[1|2|3|4]:TOTalize** configures the Counter/Totalizer for the totalize function but does not initiate the measurement procedure. Once the measurement is started, the totalize function remains active until the channel is reconfigured to another function.

Comments

- **Channel Selection:** Select only one channel at a time. The channel number defaults to channel 1 if a channel number is not specified.
- **Acceptable Channels:** Totalize function can be measured on channels 1, 2, 3, and/or 4.
- **Reading Measurement Results:** The totalize measurement must be reset and started using the INITiate command. Measurement results are read using the FETCh? command, which reads the current count without resetting the Counter/Totalizer or interrupting the measurement. Do not use the READ? command for totalize measurements.
- **Gated Totalize Measurements:** See the SENSE subsystem later in this chapter for information on gated totalize measurements. Function changes to channel 2 or 4 will disable the gating on totalize measurements (if enabled), since it can no longer function as a totalize gate while making measurements.
- **Overflow Indication:** Overflow is detected by reading the Questionable Data/Signal Register (see the STATus subsystem later in this chapter).

Note

When the counter overflows, it rolls over to zero and keeps on counting.

- **Range and Resolution:** Values for *range* and *resolution* can be entered, but are ignored. Measurement *range* is up to 4.29E9 counts.
- **Digital Low-Pass Filter:** To reduce the possibility of counting errors (that reduce the accuracy of the measurement) when using the digital low-pass filter, select the highest filter frequency setting that will eliminate the input noise.
- **Timing:** When performing totalizing measurements, the Counter/Totalizer must be given sufficient time to configure and initiate the measurement before the first event is received.

Example **Configuring Totalize Measurements**

CONF1:TOT

*Sets channel 1 function to totalize.
Does not perform measurement.*

:UDCount **CONFigure[1|3]:UDCount** configures the Counter/Totalizer to the up/down count measurement function, but does not initiate the measurement procedure. Once the measurement is started, the up/down count function remains active until the channel is reconfigured to another function.

Comments

- **Channel Selection:** Select only one channel at a time. The channel number defaults to channel 1 if a channel number is not specified.
- **Acceptable Channels:** Up/Down count can be measured on channel pairs 1 to 2 and/or 3 to 4. Select channel 1 for 1-2 measurement, and/or channel 3 for 3-4 measurement.
- **Reading Measurement Results:** The up/down count measurement must be reset and started with the **INITiate** command. The measurement results are read using the **FETCh?** command, which reads the current count without resetting the counter or interrupting the measurement. Count returned is total channel 1 count minus total channel 2 count, and/or total channel 3 count minus total channel 4 count. Do not use the **READ?** command for up/down count measurements.
- **Range and Resolution:** Values for *range* and *resolution* can be entered, but are ignored. Measurement *range* is up to 2.14E9 counts.
- **Digital Low-Pass Filter:** To reduce the possibility of counting errors (that reduce the accuracy of the measurement) when using the digital low-pass filter, select the highest filter frequency setting that will eliminate the input noise.
- **Timing:** When performing up/down counting measurements, the Counter/Totalizer must be given sufficient time to configure and initiate the measurement before the first event is received.

Example **Configuring Up/Down Count Measurements**

CONF3:UDC

Sets channel 3 and 4 function to up/down count. Does not perform measurement.

CONFigure?

CONFigure? queries a specific channel to determine the presently configured function, range, and resolution.

Subsystem Syntax CONFigure[1|2|3|4]?

Parameters Select one channel for the command (1, 2, 3, or 4). If a channel is not specified, the command acts on channel 1 which is the default.

Comments

- **Channel Selection:** Select only one channel at a time. The channel number defaults to channel 1 if a channel number is not specified.
- **Output Format:** The query will return one of the functions listed in the CONFigure subsystem, along with entered *range* and *resolution* values. If *range* or *resolution* were not specified, "AUTO, DEF" is returned (AUTO-range, DEFault resolution). Typical string returned is as follows:

FREQ, 1.0000000000E+05, 1.0000000000E 01

or

FREQ AUTO,DEF

- **UNDEFINED:** CONFigure? will return "UNDEFINED" if the configuration of the pair channel prevents measurements from being made. For example, if channel 1 is configured to frequency, CONF2? would return UNDEFINED.

Example Query Channel 2 Configuration

CONF2?

Query present configuration of channel 2.

DISPlay

The **DISPlay** command subsystem monitors the present state of the selected channel on the Counter/Totalizer module. This command is useful only with mainframes that have a front panel display, such as the Agilent 75000 Series B Mainframe (Agilent Model Number E1301B).

Subsystem Syntax

```
DISPlay
:MONitor
:CHANnel [1|2|3|4|AUTO]
:CHANnel?
[:STATe] <mode>
[:STATe]?
```

:MONitor:CHANnel

DISPlay:MONitor:CHANnel [1|2|3|4|AUTO] selects the channel to be monitored or AUTO tracking. Use the **DISPlay:MONitor:STATe** command to enable and disable the monitor mode.

Comments

- **Selecting Monitor Channel Values:** When using the **DISPlay:MONitor:CHANnel** command, numbers 1 to 4 select a specific channel to be monitored, and AUTO activates the automatic mode where the last channel to receive a command is displayed.
- **Monitor Mode on an Agilent E1301 Mainframe Display:** Selecting the channel causes the information to be displayed on the mainframe front panel. The following example shows the monitor mode display string on the display of an Agilent E1301B Mainframe:

```
COUNTER_48:  Chan 1      +1.4653026789E+06
mon  err  freq  mrng      trig:imm
```

Example shows channel 1 measurement returned with 1.4653026789 MHz, monitor on, error detected, frequency function in manual range, trigger source set to immediate.

- ***RST Condition:** DISP:MON:CHAN AUTO

Example

Selecting Channel 1 for Monitoring

```
DISP:MON:CHAN 1 Select channel 1 for monitor mode.
```

:MONitor:CHANnel?

DISPlay:MONitor:CHANnel? queries which channel will be displayed when the monitor mode is enabled. -1 indicates operating in automatic mode (displays the last channel changed). 1 through 4 indicates which specific channel will be displayed.

Example

Querying the Monitor Mode Channel

```
DISP:MON:CHAN? Query monitor mode channel.
```

:MONitor[:STATe] **DISPlay:MONitor[:STATe]** <mode> turns the monitor mode on or off.

Parameters

Parameter Name	Parameter Type	Range of Values	Default Value
mode	Boolean	OFF (0) ON (1)	OFF

Comments

- **Enabling the Monitor Function:** The [:STATe] parameter is optional. Therefore, either of the following command statements is valid and enable the monitor function:

DISP:MON:STAT ON *or* DISP:MON ON

- **Selecting the Channel to be Monitored:** Use the DISP:MON:CHAN command to select the channel to be monitored.
- **Disabling Monitor Mode:** Pressing any front panel key while in monitor mode will automatically disable the monitor function.
- ***RST Condition:** DISP:MON:STAT OFF

Example Enabling the Monitor Mode

DISP:MON:STAT 1 *Turns monitor mode on.*

:MONitor[:STATe]? **DISPlay:MONitor[:STATe]?** returns a number indicating whether the monitor mode is enabled or disabled: "1" = ON, "0" = OFF. The value is sent to the output buffer.

Comments

- This command is valid only when executed from your computer over the interface bus. The monitor mode is automatically disabled if executed from the mainframe's front panel.
- The [:STATe]? parameter is optional. Therefore, either of the following command statements is valid:

DISP:MON:STAT? *or* DISP:MON?

Example Querying the Monitor Mode

DISP:MON:STAT? *Query the present state of the monitor mode.*

FETCh?

The **FETCh?** command retrieves measurements stored in mainframe/command module memory by the most recent **INITiate** command and places them in the output buffer.

Subsystem Syntax FETCh[1|2|3|4]?

Comments

- **Channel Selection:** Select only one channel at a time. The channel number defaults to channel 1 if a channel number is not specified.
- **FETCh? and INITiate:** Perform a measurement using the **INITiate** command before sending the **FETCh?** command. If the **INITiate** command has not been executed, **FETCh?** will generate an error.
- **Output Format:** Previous data stored in the output buffer is lost when a **FETCh?** is executed. Typical string returned is as follows:

 +1.2345678901E +006
- **TOTALize and UDCount Measurements:** If the selected channel is configured for totalize, gated totalize, or up/down count, **FETCh?** reads the current value from the Counter/Totalizer and returns the result.

Example Transferring a Measurement to Output Buffer

FETCh1?

Transfers completed channel 1 measurement result to the output buffer.

INITiate

The **INITiate** command initiates a measurement by controlling the channel's trigger state. Executing an **INITiate** command changes the channel trigger from the "idle" state to the "wait-for-trigger" state.

Subsystem Syntax `INITiate[1|2|3|4]`

Comments

- **Channel Selection:** Select only one channel at a time. The channel number defaults to channel 1 if a channel number is not specified.
- **Performing the Measurement:** After the trigger system is initiated using **INIT**, the state of the **TRIGger** command subsystem controls when the actual measurement occurs. (See the **TRIGger** subsystem later in this chapter for more information.)

If **TRIGger:SOURce** is **IMMEDIATE** (the default for **TRIG:SOUR**), the measurement is performed as soon as **INITiate** is executed. The measurement result is stored in mainframe/command module memory. A measurement stored in memory from a previous command is replaced by the new measurement data.

If **TRIGger:SOURce** is set to **BUS** or **HOLD**, the measurement will only be performed after the appropriate trigger command is executed.

- **Measurement Result:** After the **TRIG:IMMEDIATE** command has executed, the measurement result is stored in mainframe/command module memory. Use **FETCH?** to transfer the measurement to the output buffer.

Example Initiating the Measurement

`INIT3`

*Performs configured measurement on channel 3 and stores result if **TRIG:SOUR IMM** (default).*

INPut

The **INPut** subsystem commands control the input signal conditioning parameters for all channels (1 through 4) simultaneously. Parameters controlled by INPut are the state and frequency of the digital low-pass filter, and the selection of the isolated or non-isolated terminals.

Subsystem Syntax

```
INPut[1|2|3|4]
:FILTer
[:LPASs]
:FREQUency <frequency | MIN | MAX | DEF>
:FREQUency?
[:STATe] <state>
[:STATe]?
:ISOLate <state>
:ISOLate?
```

:FILTer[:LPASs] :FREQUency

INPut[1|2|3|4]:FILTer[:LPASs]:FREQUency <frequency | MIN | MAX | DEF> sets the digital low-pass input filter to a specific frequency.

Parameters

Parameter Name	Parameter Type	Range of Values	Default Value
<i>frequency</i>	Numeric	4 Hz - 131.072E3 Hz, MIN MAX DEF	131.072 kHz

Comments

- **Channel Selection:** It is unnecessary to select a channel number as the INPut commands affect all channels simultaneously.
- **Acceptable Frequencies:** Cut-off frequency is programmable in Hz in 16 binary steps from 4 Hz to 131.072 kHz. If a value is entered that is not an exact step, the next higher binary value is selected. Selecting MIN enters 4 Hz, selecting DEF or MAX enters 131.072 kHz. Selecting a value higher than 131.072 kHz generates an error.
- **Cut-off Frequency:** The digital low-pass input filter is a sampling digital filter that passes or rejects input signals based on frequency without regard to amplitude. For input signals with a 50% duty cycle, the digital filter will pass ALL signals below the selected cut-off frequency, and reject ALL signals greater than 2 times the selected cut-off frequency. For signals in between, the output of the digital low-pass filter will be a signal with a frequency less than or equal to input frequency.

For example, the input to the filter is a signal from 0 Hz to 8.192 kHz. The filter cutoff frequency is programmed to 4096 Hz. The figure illustrates the output of the filter. At 4096 Hz input, the output is 4096 Hz, and at 8.192 kHz input, the output is 0 Hz. With inputs 4096 Hz to 8.192 kHz, the output is a frequency less than or equal to the input frequency.

- **Selecting a Cut-off Frequency:** When calculating the cut-off frequency, use the following as a guide:

Input signal not 50% duty cycle:

$$\text{filter frequency} > \frac{1}{2x (\text{minimum pulse width to be passed})}$$

Input signal 50% duty cycle, filter frequency > input frequency.

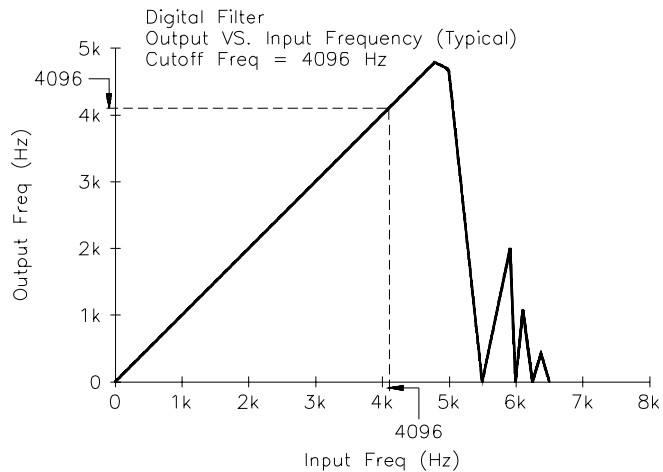

- **Quantizing Errors:** Because the digital low-pass input filter is a sampling digital filter, passing signals close to the selected cut-off frequency can generate a quantizing error. The error (jitter) can be up to 10% of the selected cutoff frequency. These errors are most noticeable when measuring pulse width and time interval or period average. To minimize the possibility for encountering quantizing errors, choose a filter frequency as high as possible for the noise present on the input signal.
- ***RST Condition:** INP:FILT:LPAS:FREQ 131072

Example Setting the Digital Low-Pass Filter to 8.192 kHz

INP:FILT:FREQ 8.192E3 *Set filter frequency to 8.192 kHz.*

**:FILTer[:LPASs]
:FREQuency?**

INPut[1|2|3|4]:FILTer[:LPASs]:FREQuency? queries the present value of the digital low-pass filter frequency.

Comments

- **Channel Selection:** It is unnecessary to select a channel number as the INPut commands affect all channels simultaneously.
- **Output Format:** Returned frequency will be in Hz in binary steps from 4 Hz to 131.072 kHz. The measurement is placed in the output buffer. Typical string returned is as follows:

+1.31072000E+005

Example Querying the Selected Digital Low-Pass Filter Frequency

INP:FILT:FREQ? *Query the selected low-pass filter frequency.*

**:FILTer[:LPASs]
[:STATe]** **INPut[1|2|3|4]:FILTer[:LPASs][:STATe] <state>** enables or disables the digital low-pass input filter.

Parameters

Parameter Name	Parameter Type	Range of Values	Default Value
<i>state</i>	Boolean	OFF (0) ON (1)	OFF

Comments

- **Channel Selection:** It is unnecessary to select a channel number as the INPut commands affect all channels simultaneously.
- **Selecting Filter:** ON or 1 enables the filter, OFF or 0 disables the filter for all four channels simultaneously.
- **Switch Debounce:** When counting events from mechanical switches, the digital low-pass input filter should be used whenever possible to eliminate contact bounce.
- ***RST Condition:** INP:FILT:LPAS:STAT 0 | OFF

Example Setting the Digital Low-Pass Filter to ON

INP:FILT ON

Enables the digital low-pass filter on all channels.

**:FILTer[:LPASs]
[:STATe]?** **INPut[1|2|3|4]:FILTer[:LPASs][:STATe]?** is used to query the present state of the digital low-pass input filter.

Comments

- **Channel Selection:** It is unnecessary to select a channel number as the INPut commands affect all channels simultaneously.
- **Output Format:** Returns a 1 if the digital low-pass filter is on or enabled, and a 0 if the digital low-pass filter is off or disabled.

Example Querying the Digital Low-Pass Filter State

INP:FILT?

Query low-pass filter state.

:ISOLate INPut[1|2|3|4]:ISOLate <state> enables or disables the isolated input terminals.

Parameters

Parameter Name	Parameter Type	Range of Values	Default Value
<i>state</i>	Boolean	1 0 ON OFF	0 OFF

Comments

- **Channel Selection:** It is unnecessary to select a channel number as the INPut commands affect all channels simultaneously.
- **Channels Effected:** ON or 1 enables the isolated input terminals, OFF or 0 disables the isolated input terminals for all four channels.
- **Noise:** The isolated input terminals should be used whenever measuring in high common mode noise environments.
- ***RST Condition:** INP:ISOL 0 | OFF

Caution

MAXIMUM VOLTAGE. The maximum voltage that may be applied to any ISOLATED input connector is 6.4 V at 6.3 mA.

Example

Set Isolated Input Terminals to ON

INP:ISOL ON

Enables the isolated input terminals for all channels.

:ISOLate?

INPut[1|2|3|4]:ISOLate? is used to display the present state of the input terminals.

Comments

- **Channel Selection:** It is unnecessary to select a channel number as the INPut commands affect all channels simultaneously.
- **Output Format:** Returns a 1 if the isolated input terminals are selected, and a 0 if the non-isolated input terminals are selected.

Example

Querying the Input Terminals State

INP:ISOL?

Query input terminal state.

MEASure

The **MEASure** command subsystem sets up the Counter/Totalizer to perform a specified measurement either in AUTO range or on a manually entered range, and then performs the measurement. After the measurement is performed, the reading is placed in mainframe memory and the output buffer.

Subsystem Syntax

```
MEASure[1|2|3|4]
:FREQuency? [<range>,<resolution>]
:NWIDth?*
:PERiod? [<range>,<resolution>]
:PWIDth?*
:TINTerval?*
```

Comments

- ***Range and Resolution Ignored:** The optional parameters (*range* and *resolution*) are ignored for NWIDth, PWIDth, and TINTerval measurements.
- **Specifying Range and/or Resolution:** If the optional parameters are to be used, you can enter a value for *range* and not *resolution*, but you cannot enter a value for *resolution* alone. If a value for *resolution* is entered, a value for *range* must also be entered.
- **Manual Range:** If the optional parameters *range* and *resolution* are specified, the Counter/Totalizer will set-up and perform the measurement using the values entered. A slightly faster measurement is made when *range* is specified since a sample measurement to determine the correct range is unnecessary.
- **Auto Range:** If the optional parameters *range* and *resolution* are not entered, the input signal is sampled to determine the proper *range* setting. *Resolution* is set for a default *resolution* of 5 digits.
- **MEASure and CONFigure versus SENSE:** Most measurements can be performed using one of these three subsystems, and each has advantages and disadvantages over the other. The differences in the commands are:

The CONFigure command can be used for all measurements. The CONFigure command only configures a channel for a specific function, and does not perform the measurement. Use of additional commands (READ? or INIT/FETC?) to perform the measurement and read the results is necessary. The choice of manual or AUTO ranging for frequency and period functions is provided through the use of optional parameters.

The MEASure command can be used for all measurements except gated totalize, totalize, and up/down count. The MEASure command configures a channel for a specific function, performs the measurement, and returns the results. The choice of manual or AUTO ranging for frequency and period functions is provided through the use of optional parameters.

Both CONFIGure and MEASure commands are instrument independent and can be used in other instruments to perform similar functions. These commands should be used when the portability of instrument syntax is important.

The SENSE subsystem can be used for all measurements. The SENSE:FUNCTION command only configures a channel for a specific function and does not perform the measurement. Use of additional commands (READ? or INIT/FETC?) to perform the measurement and store the results is necessary. Only manual ranging for frequency and period functions is provided, and these parameters may be entered using an additional command (SENS:FREQ:APER or SENS:PER:NPER).

The SENSE commands are instrument dependent and may behave differently in other instruments. These commands should be used when direct control over the measurement is important.

Note SENSE:FUNCTION:FREQ is a good choice when the input signal may have a frequency of zero. This function always completes. CONF n :FREQ or MEAS n :FREQ may automatically select the PERiod function which will not complete when the frequency is zero.

:FREQUENCY? MEASure[1|3]:FREQUENCY? [*<range>* [,*<resolution>*]] configures the Counter/Totalizer to the frequency measurement function, performs the measurement, and transfers the results to the output buffer.

Parameters

Parameter Name	Parameter Type	Range of Values	Default Value
<i>range</i>	Numeric	2E-3 to 4E6 Hz MIN MAX AUTO	AUTO
<i>resolution</i>	Numeric	5.4E-13 to 500 Hz MIN MAX	5 digits

Comments

- **Channel Selection:** Select only one channel at a time. The channel number defaults to channel 1 if a channel number is not specified.
- **Acceptable Channels:** Frequency can be measured on channels 1 and/or 3. Depending on the settings, this measurement can continue indefinitely if there is no input signal.
- **Overflow Indication:** Overflow is detected by querying the Questionable Data/Signal Register (see the STATus subsystem later in this chapter).
- **Entering Range:** *Range* can be entered as a number in Hz from 0.002 Hz to 4 MHz. AUTO range is selected when *range* is not

specified. Refer to the section titled “Selecting Range and Resolution” on page 50 for more information.

- **Entering Resolution:** *Resolution* can be entered as a number in Hz from 5.4E-13 Hz to 500 Hz. Entries up to 4E6 are accepted. *Resolution* is automatically set to 5 digits by not entering values for *range* and *resolution*. If *resolution* is entered, *range* must also be entered. Refer to the section titled “Selecting Range and Resolution” on page 50 for more information.

Example Making Frequency Measurements

MEAS3:FREQ? 1E6,10

Sets channel 3 function to frequency, range to 1 MHz, and resolution to 10 Hz, performs measurement, and transfers result to the output buffer.

:NWIDth? **MEASure[2|4]:NWIDth?** configures the Counter/Totalizer to the negative pulse width measurement function, performs the measurement, and transfers the results to the output buffer.

Comments

- **Channel Selection:** Select only one channel at a time.
- **Acceptable Channels:** Negative pulse width can be measured on channels 2 and/or 4. The measurement will continue indefinitely until the second edge is detected.
- **Edge Select:** Negative pulse width is measured from the falling edge to the rising edge.
- **Overflow Indication:** Overflow is detected by reading the Questionable Data/Signal Register (see the STATus subsystem later in this chapter).
- **Range and Resolution:** Values for *range* and *resolution* can be entered, but are ignored. Measurement *range* is from 500 nsec to 858 sec, and *resolution* is fixed at 200 nsec.
- **Digital Low-Pass Filter:** To reduce the possibility of counting errors (that reduce the accuracy of the measurement) when using the digital low-pass filter, select the highest filter frequency setting that will eliminate the input noise.

Example Making Negative Pulse Width Measurements

MEAS4:NWID?

Sets channel 4 function to negative pulse width, performs measurement, and transfers result to the output buffer.

:PERiod? **MEASure[1|3]:PERiod? [<range>[,<resolution>]]** configures the Counter/Totalizer to the period average measurement function on channel 1 or 3, performs the measurement, and transfers the results to the output buffer.

Parameters

Parameter Name	Parameter Type	Range of Values	Default Value
<i>range</i>	Numeric	250E-9 to 429 sec MIN MAX AUTO	AUTO
<i>resolution</i>	Numeric	9.6E-16 to .002 sec MIN MAX DEF	5 digits

Comments

- **Channel Selection:** Select only one channel at a time. The channel number defaults to channel 1 if a channel number is not specified. Channels 2 and 4 cannot make period measurements.
- **Acceptable Channels:** Period average can be measured on channels 1 and/or 3.
- **Type of Signal Measured:** Signals must be periodic for the period function.
- **Entering Range:** *Range* is entered as a number in seconds from 250 nsec to 429 seconds. The Counter/Totalizer uses AUTO range when the *range* parameter is not specified. Refer to the section titled “Selecting Range and Resolution” on page 50 for more information.
- **Entering Resolution:** *Resolution* can be entered as a number in seconds from 9.6E-16 to .002 seconds. Entries up to 858 seconds will be accepted. *Resolution* is automatically set to 5 digits if *range* and *resolution* are not specified in the command. If *resolution* is entered, it must be preceded by a *range* value. Refer to the section titled “Selecting Range and Resolution” on page 50 for more information.
- **Overflow Indication:** Overflow can be detected by reading the Questionable Data/Signal Register (see the STATus subsystem later in this chapter).

Example Making Period Average Measurements

MEAS3:PER? 1E-3,1E-7

Sets channel 3 function to period, range to 1 msec and resolution to 100 nsec, performs measurement, transfers result to the output buffer.

:PWIDth? **MEASure[2|4]:PWIDth?** configures the Counter/Totalizer to the positive pulse width measurement function on channels 2 or 4, performs the measurement, and transfers the results to the output buffer.

Comments

- **Channel Selection:** Select only one channel at a time.
- **Acceptable Channels:** Positive pulse width can be measured on channels 2 and/or 4. The measurement will continue indefinitely until the second edge is detected.
- **Edge Select:** Positive pulse width is measured from the rising edge to the falling edge.
- **Overflow Indication:** Overflow is detected by reading the Questionable Data/Signal Register (see the STATus subsystem later in this chapter).
- **Range and Resolution:** Values for *range* and *resolution* can be entered, but are ignored. Measurement *range* is from 500 nsec to 858 sec, and *resolution* is fixed at 200 nsec.
- **Digital Low-Pass Filter:** To reduce the possibility of counting errors (that reduce the accuracy of the measurement) when using the digital low-pass filter, select the highest filter frequency setting that will eliminate the input noise.

Example Making Positive Pulse Width Measurements

MEAS2:PWID?

Sets channel 2 function to positive pulse width, performs measurement, and transfers result to the output buffer.

:TINterval? **MEASure[1|3]:TINterval?** configures the Counter/Totalizer to the time interval measurement function on channels 1 or 3, performs the measurement, and transfers the results to the output buffer.

Comments

- **Channel Selection:** Select only one channel at a time. The channel number defaults to channel 1 if a channel number is not specified.
- **Acceptable Channels:** Time interval can be measured on channel pairs 1 to 2 and/or 3 to 4. Select channel 1 for 1-2 measurement, and/or channel 3 for 3-4 measurement. Events are measured from channel 1 to channel 2 and/or channel 3 to channel 4. The measurement will continue indefinitely until the second edge is detected.
- **Start and Stop Edges:** The edges of both the start and stop channels can be selected using the **SENSE:SLOPe** command. Unless changed, the measurement will be performed using the presently selected slope.
- **Overflow Indication:** Overflow is detected by reading the Questionable Data/Signal Register (see the **STATus** subsystem later in this chapter).
- **Range and Resolution:** Values for *range* and *resolution* can be entered, but are ignored. Measurement *range* is from 500 nsec to 858 sec, and *resolution* is fixed at 200 nsec. Refer to the section titled “Selecting Range and Resolution” on page 50 for more information.
- **Digital Low-Pass Filter:** To reduce the possibility of counting errors (that reduce the accuracy of the measurement) when using the digital low-pass filter, select the highest filter frequency setting that will eliminate the input noise.

Example Making Time Interval Measurements

MEAS3:TINT?

Sets channels 3 and 4 function to time interval, performs measurement, and transfers result to the output buffer.

READ?

The **READ?** command is used to initiate a configured measurement and then transfer the measurement result to the output buffer. The **READ?** command performs the identical function as an **INITiate** and **FETCh?** command.

Subsystem Syntax

READ[1|2|3|4]?

Comments

- **Channel Selection:** Specify only one channel at a time. If a channel is not specified, the command defaults to channel 1.
- **READ? or INIT/FETC?:** The **READ?** command cannot be used with **TOTALize** and **UDCount** because both functions do not complete (continue counting). See **INITiate** and **FETCh?** commands for reading results of these functions.
- **Output Format:** After the measurement is complete, the results are sent to the output buffer. Previous data in the output buffer is lost when the **READ?** command is executed. Typical string returned is as follows:

+1.2345678901E+006

Example Transferring Readings Directly to Output Buffer

READ3?

Performs configured measurement on channel 3 and transfers result to output buffer.

[SENSe:]

The [SENSe:] command subsystem can be used to manually configure all available measurements, and/or enter various measurement parameters. The [SENSe:] command offers direct manual control of measurement functions and parameters.

When using the [SENSe:] subsystem to configure frequency or period measurements, the aperture time and number of periods can be verified and/or changed. Additionally, event slope and event level for all measurements using CONFigure, MEASure, or SENSE can be verified and/or changed using the [SENSe:] subsystem.

[SENSe:] enables you to change the following settings:

- Trigger Level
- Trigger Slope
- Function
- Aperture Time
- Number of Periods

Subsystem Syntax

```
[SENSe[1|2|3|4]:]
  EVENT
    :LEVel <number | MIN | MAX | DEF>
    :LEVel?
    :SLOPe <POS | NEG>
    :SLOPe?
  FREQuency
    :APERTure <number | MIN | MAX | DEF>
    :APERTure?
  FUNction
    :FREQuency
    :NWIDth
    :PERiod
    :PWIDth
    :TINTerval
    :TOTalize
    :UDCount
  FUNction?
  PERiod
    :NPERiods <number | MIN | MAX | DEF>
    :NPERiods?
  TOTalize
    :GATE
    :POLarity <polarity>
    :POLarity?
    [:STATe] <state>
    [:STATe]?
```

EVENT:LEVel [SENSe[1|2]:]EVENT:LEVel <*number* | MIN | MAX | DEF> specifies the event level for channels pairs 1 - 2, and/or 3 - 4. The channel number defaults to channel 1 if a channel number is not specified.

Parameters

Parameter Name	Parameter Type	Range of Values	Default Value
<i>number</i>	Numeric	-2.56V to +2.54V MIN MAX DEF	0 V

Comments

- **Programming Channels:** Event level is programmable in 20 mV steps on channels pairs only. Select only one channel at a time, and enter either number in the channel pair. Each channel pair can have a different event level programmed. Values entered outside the range will generate an error.
- **Level Jumpers:** When the level jumpers are in the normal position, entered levels of -2.56 to +2.54 V in 20 mV steps behave as entered. When the level jumpers are in the /10 position, levels are entered as -2.56 to +2.54 V in 20 mV steps, but behave as -25.6 to +25.4 V in 200 mV steps.
- ***RST Condition:** SENS:EVEN:LEV 0

Example Set Channel Pair 1-2 Event Level to -1.0V

SENS2:EVEN:LEV-1

Sets channel 1 and channel 2 event level to -1.00V

EVENT:LEVel? [SENSe[1|2|3|4]:]EVENT:LEVel? queries the currently selected event level on the specified channel pair.

Comments

- **Channel Selection:** Select only one channel at a time, and enter either number in the channel pair. The channel number defaults to channel 1 if a channel number is not specified.
- **Output Format:** Returned level will be in volts from -2.56 to +2.54. The measurement is placed in the output buffer. Typical string returned is as follows:

+2.56000000E+000

Example Querying the Event Level Setting of Channel 1

SENS1:EVEN:LEV?

Query channel pair 1-2 for present event level.

EVENT:SLOPe [SENSe[1|2|3|4]:]EVENT:SLOPe <POSitive | NEGative> specifies either the POSitive (rising) or NEGative (falling) edge of the input signal as the sense event slope for the measurement. Each channel's slope can be set independently.

- Comments**
- **Channel Selection:** Select only one channel at a time. The channel number defaults to channel 1 if a channel number is not specified.
 - **Measurements Using Slope:** The slope setting is ignored for both positive and negative pulse width measurements; changing the slope on these functions would give a different measurement result. The slope setting is used on all other measurements.
 - ***RST Condition:** SENS:EVEN:SLOP POS

Example Set Channel 2 Event Slope to Negative

SENS2:EVEN:SLOP NEG *Sets channel 2 event slope to negative.*

EVENT:SLOPe? [SENSe[1|2|3|4]:]EVENT:SLOPe? queries a specific channel about the currently selected slope polarity. Returns POS if slope is set for positive and NEG if slope is set negative.

- Comments**
- **Channel Selection:** Select only one channel at a time. The channel number defaults to channel 1 if a channel number is not specified.

Example Querying the Slope Setting of Channel 2

SENS2:EVEN:SLOP? *Query slope polarity on channel 2.*

FREQUENCY :APERTURE

[SENSe[1|2|3|4]:]FREQUENCY:APERture <number | MIN | MAX | DEF> specifies the aperture time for a frequency measurement. Table 4-2 on page 52 shows the sixteen resolution choices you have for frequency, the corresponding aperture time, and the maximum frequency for 3- to 6-digit resolution. The resolution choices are limited to the sixteen steps of aperture time using the direct frequency measurement technique. Table 4-3 on page 53 shows the sixteen resolution choices you have for frequency measurements using the period averaging technique.

Parameters

Parameter Name	Parameter Type	Range of Values	Default Value
<i>number</i>	Numeric	2 mS to 65.536 sec MIN MAX DEF	2 mS

Comments

- **Channel Selection:** Select only one channel at a time. The channel number defaults to channel 1 if a channel number is not specified.
- **Aperture Time versus Resolution:** Aperture time is the gate width in which frequency measurements are made using the SENSe:FUNcTION command. A larger aperture time is required to obtain greater resolution. Refer to the section titled “Selecting Aperture Time and Number of Periods” on page 51 for more information.
- **Selecting Aperture Time:** Aperture time is programmable in 16 binary steps from 2 mS to 65.536 seconds (MIN to MAX i.e., 2, 4, 8, 16, 32, 64 mS, etc.). If an aperture time is specified that is not an exact step, the next highest step is used. Selecting DEF or MIN enter 2E-3 seconds; MAX enters 65.536 seconds. Specifying a value out of range will generate an error.
- ***RST Condition:** SENS:FREQ:APER 2E-3

Example Set Channel 1 Frequency Aperture Time to 128 mS

```
SENS1:FREQ:APER 128E-3
```

Sets channel 1 frequency aperture time to 128 mS.

FREQUENCY :APERTURE?

[SENSe[1|3]:]FREQUENCY:APERture? [MIN | MAX | DEF] returns one of the following numbers to the output buffer:

- The current aperture time in seconds if no parameter is specified.
- The minimum aperture time available if MIN is specified.
- The maximum aperture time available if MAX is specified.
- The default aperture time if DEF is specified.

Comments

- **Channel Selection:** Select only one channel at a time. The channel number defaults to channel 1 if a channel number is not specified.
- **Output Format:** The query will return a result in seconds from 2 msec to 65.536 seconds. The measurement is placed in the output buffer. Typical string returned is as follows:

8.19200000E+000

Example Querying the Aperture Time

SENS3:FREQ:APER?

Query channel 3 for currently selected aperture time.

FUNCTION You specify the measurement function with the following command:

[SENSe[1|2|3|4]:]FUNctioN:<*function*>

This command is used to set up the Counter/Totalizer to perform a specified measurement in manual range but does not perform the actual measurement. Depending on measurement function selected, additional SENSE commands may need to be executed.

Parameters

Parameter Name	Parameter Type	Range of Values	Default Value
<i>function</i>	Discrete	FREQuency PERiod UDCount TINterval PWIDTH NWIDTH TOTalize	FREQ

Comments

- **Channel Selection:** Select only one channel at a time. The channel number defaults to channel 1 if a channel number is not specified.
- **Selecting the Sensor Function:** Depending on the sensor function selected, additional SENSE commands may need to be executed before proceeding with the measurement.
 - If function is FREQuency, use the SENSE:FREQuency:APERture command to enter aperture time.
 - If function is PERiod, use the SENSE:PERiod:NPERiod command to enter number of periods.
- **Measurement Description:** See the CONFigure subsystem earlier in this chapter for a description of all available measurements, except gated totalize.
- **Gated Totalize Measurements:** See SENSE:TOTalize later in this subsystem for information on gated totalize measurements.
- **SENSe versus MEASure and CONFigure:** Most measurements can be performed using one of these three subsystems, and each has advantages and disadvantages over the other. The differences in the commands are:

The CONFigure command can be used for all measurements. The CONFigure command only configures a channel for a specific function, and does not perform the measurement. Use of additional commands (READ? or INIT/FETC?) to perform the measurement and read the results is necessary. The choice of manual or AUTO ranging for frequency and period functions is provided through the use of optional parameters.

The MEASure command can be used for all measurements except gated totalize, totalize, and up/down count. The MEASure command configures a channel for a specific function, performs the measurement, and returns the result to the output buffer. The choice of manual or AUTO ranging for frequency and period functions is provided through the use of optional parameters.

Both CONFigure and MEASure commands are instrument independent and can be used in other instruments to perform similar functions. Use these commands when the portability of instrument syntax is important.

The SENSE subsystem can be used for all measurements. The SENSE:FUNCTION command only configures a channel for a specific function and does not perform the measurement. Use of additional commands (READ? or INIT/FETC?) to perform the measurement and store the results is necessary. Only manual ranging for frequency and period functions is provided, and these parameters may be entered using an additional command (SENS:FREQ:APER or SENS:PER:NPER).

The SENSE commands are instrument dependent and may behave differently in other instruments. These commands should be used when direct control over the measurement is important.

Note SENSE:FUNCTION:FREQ is a good choice when the input signal may have a frequency of zero. This function always completes. CONF n :FREQ or MEAS n :FREQ may automatically select the PERIOD function which will not complete when the frequency is zero.

Example Set Channel 1 Function to Positive Pulse Width

SENS1:FUNC:PWID *Set channel 1 to positive pulse width.*

FUNCTION? [SENSE[1|2|3|4]:]FUNCTION? queries the Counter/Totalizer to determine the sensor function selected by the SENSE:FUNCTION command for a specific channel. The query will return one of the following functions listed in the SENSE:FUNCTION command section: FREQ, PER, UDC, TINT, PWID, NWID, TOT, or UNDEFINED.

Comments

- **Channel Selection:** Select only one channel at a time. The channel number defaults to channel 1 if a channel number is not specified.

Example Querying Channel 3 Sensor Function

SENS3:FUNC? *Query channel 3 to return currently selected function.*

PERiod:NPERiods

[SENSe[1|3]:]PERiod:NPERiods <number | MIN | MAX | DEF> is used to enter the number of periods for a period average measurement configured using the SENSe:FUNCTion command. All period measurements are made by averaging from 2 to 65536 periods.

Parameters

Parameter Name	Parameter Type	Range of Values	Default Value
<i>number</i>	Numeric	2 to 65536 periods MIN MAX DEF	2

Comments

- **Channel Selection:** Select only one channel at a time. The channel number defaults to channel 1 if a channel number is not specified.
- **Selecting Number of Periods to Average:** Number of periods is programmable in 16 binary steps from 2 to 65536 (MIN to MAX i.e., 2, 4, 8, 16, 32, 64, etc.). If a value is specified that is not an exact step, the next highest binary value is selected. Selecting DEF or MIN enters 2 cycles, and MAX enters 65536 cycles. Selecting a value out of range will generate an error.
- **Number of Periods versus Resolution:** Number of Periods is the number of periods that are measured and averaged for period measurements made using the SENSe:FUNCTion command. A larger number of periods is required to obtain greater resolution. Refer to the section titled “Selecting Aperture Time and Number of Periods” on page 51 for more information.
- ***RST Condition:** SENS:PER:NPERS 2

Example Set Channel 1 Number of Periods to 256

```
SENS1:PER:NPERS 256
```

Sets channel 1 number of periods to average to 256.

PERiod:NPERiods?

[SENSe[1|3]:]PERiod:NPERiods? queries the currently selected number of periods on the specified channel.

Comments

- **Channel Selection:** Select only one channel at a time. The channel number defaults to channel 1 if a channel number is not specified.
- **Output Format:** The query will return the number of periods from 2 to 65536 periods. Typical string returned is as follows:

8.1920000E+003

Example Querying the Number of Periods

```
SENS3:PER:NPERS?
```

Query channel 3 to return the number of periods selected.

TOTALize:GATE

[SENSE[1|2|3|4]:]TOTALize:GATE configures gated totalizing on the Counter/Totalizer. In order to select gated totalize, the totalizing channels (1 or 3) must be CONFIGured to totalize, and the gating channels (2 or 4) must have SENSE:TOTALize:GATE:STATE set to on. The polarity of the gate can be verified/changed using the SENSE:TOTALize:GATE:POLarity command. Both commands are described later in this chapter.

Comments

- **Channel Selection:** Gated totalize measurements are performed using channel pairs (1-2, and/or 3-4). Channel 2 gates the count accumulating on channel 1, and/or channel 4 gates the count accumulating on channel 3.
- **Reading Measurement Results:** The gated totalize measurement must be reset and started using the INITiate command. The measurement results are read using the FETCH? command, which reads the current count and does not reset or interrupt the measurement. Do not use the READ? command for gated totalize measurements.
- **Overflow Indication:** Overflow is detected by reading the Questionable Data/Signal Register (see the STATus subsystem later in this chapter).

:POLarity

[SENSE[2|4]:]TOTALize:GATE:POLarity <polarity> sets the polarity of the gate for gated totalize measurements.

Parameters

Parameter Name	Parameter Type	Range of Values	Default Value
<i>polarity</i>	Discrete	NORMAL INVERTed	NORM

Comments

- **Channel Selection:** Select only one channel at a time.
- **Command Function:** Polarity is only used during gated totalize measurements to enable counts to accumulate on channel 1 or 3, while the gate channel (channel 2 or 4) is either high (NORMAL) or low (INVERTed).

Example

Set Channel 2 Gated Totalize Polarity to Low

```
SENS2:TOT:GATE:POL INV
```

Sets channel 1-2 gated totalize function to count events on channel 1 when gate on channel 2 is low.

:POLarity?

[SENSE[2|4]:]TOTALize:GATE:POLarity? queries the currently selected gate channel polarity.

Comments

- **Channel Selection:** Select only one channel at a time.
- **Output Format:** Returns NORM if the gate channel polarity is set high, and INV if the gate channel polarity is set low.

Example Querying the Gated Totalize Polarity of Channel 2

SENS2:TOT:GATE:POL?

Query the gate polarity selected on channel 2.

[[:STATE] [SENSe[2|4]:]TOTAlize:GATE[:STATE] <state> disables the gating on totalize measurements.

Parameters

Parameter Name	Parameter Type	Range of Values	Default Value
state	Boolean	1 0 ON OFF	ON OFF

Comments

- **Channel Selection:** Select only one channel at a time.
- **Channel Undefined:** Enabling the gate state sets the specified channel's function to "UNDEFINED", since it cannot make a measurement while acting as the totalize gate.
- **Channels Effected:** ON or 1 enables, and OFF or 0 disables gating on totalize measurements on the specified channel pair.
- ***RST Condition:** SENS:TOT:GATE 0 | OFF

Example Set Gated Totalize Measurement Function to ON

SENS2:TOT:GATE ON

Enables gating on the totalize measurement on channel pair 1-2.

[[:STATE]? [SENSe[2|4]:]TOTAlize:GATE[:STATE]? is used to display whether totalize measurements are being gated.

Comments

- **Channel Selection:** Select only one channel at a time.
- **Output Format:** Returns a 1 if the gated totalize measurement function is on or enabled, and a 0 if off or disabled.

Example Querying the Gated Totalize Measurement State

SENS2:TOT:GATE?

Query if totalize measurements on channel pair 1-2 are being gated.

STATus

The **STATus** subsystem reports measurement overflows by reading the bit value of the Questionable Data/Signal Register. Only bits 9 through 12 are used by the Agilent E1332A Counter/Totalizer.

Subsystem Syntax

```

STATus
:QUEStionable
:CONDition?
:ENABle <number>
:ENABle?
[:EVENt]?
    
```

The STATus system contains four registers, two of which are under IEEE 488.2 control. These are the Standard Event Status Register (*ESE) and the Status Byte Register (*STB). Refer to the appropriate mainframe or command module operating manual for more information on these registers.

The two registers under Counter/Totalizers control are the Standard Operational Status Register, and the Questionable Data/Signal Register. The Standard Operational Status Register is not used in the Counter/Totalizer and will not be discussed. The Questionable Data/Signal Register is discussed below. The figure shown below illustrates the STATus system Registers. The various registers are set and queried using decimal weighted bit values. The decimal equivalent for bits 0 to 15 is shown below.

Bit Number to Decimal Value

Bit #	0	1	2	3	4	5	6	7	8	9	10	11	12	13	14	15
Decimal Value	1	2	4	8	16	32	64	128	256	512	1024	2048	4096	8192	16384	32768

Sending a decimal value of 4608 will set bits 9 and 12 true (1).

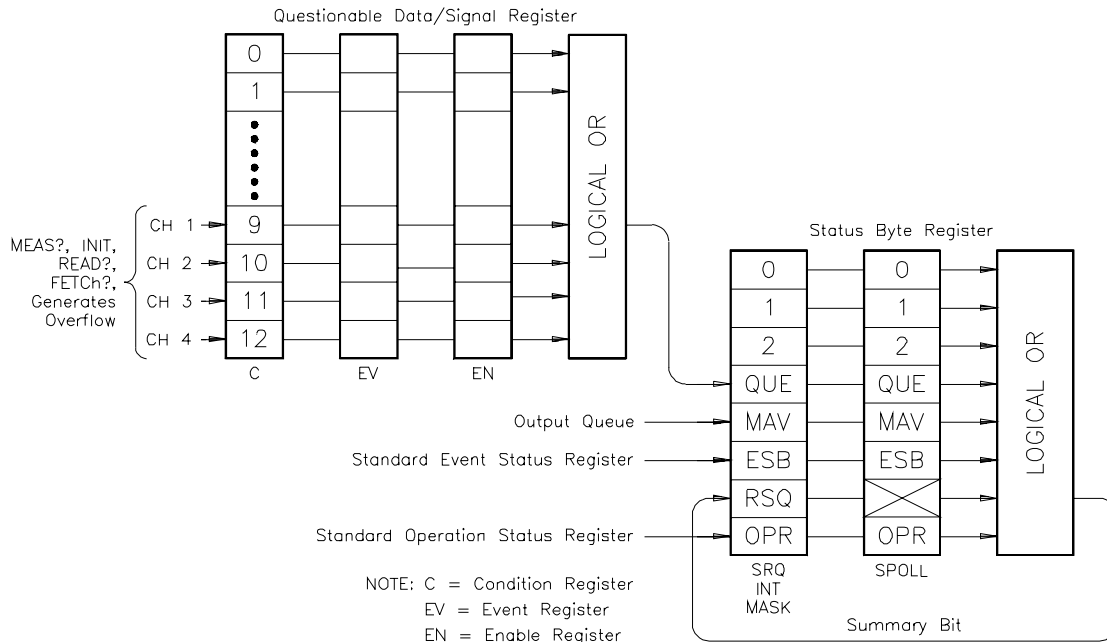

:QUESTIONable **STATus:QUESTIONable** subsystem commands query the Questionable Data/Signal Register to indicate whether an overflow has occurred on a given channel after an INIT, FETC?, READ?, or MEASure command has executed. Bit 9 of the Questionable Data/Signal Register reports overflow on channel 1, channel 2 uses bit 10, and channel 3 uses bit 11, and channel 4 uses bit 12. When any of the four bits are set to 1, bit 3 of the Status Byte Register is set to 1 if enabled by the STAT:QUES:ENAB command.

:QUESTIONable :CONDITION? **STATus:QUESTIONable:CONDition?** queries the contents of the Questionable Data/Signal Condition Register. The contents of the Condition Register reflect the state of the last measurement on each particular channel.

- Comments**
- **Information Updated:** The Condition Register is updated whenever a measured value is read from the Counter/Totalizer (MEAS?, INIT, READ?, and FETC? commands).
 - **Output Format:** Returns a decimal weighted value from 0 to 7680 indicating which bits are set true.
 - **Reading Contents:** Reading the Condition Register does not destroy its contents.

Example **Read the Questionable Condition Register**

STAT:QUES:COND? *Queries the Questionable Data/Signal Condition Register, without clearing the contents.*

:QUESTIONable :ENABLE **STATus:QUESTIONable:ENABLE <number>** sets the enable mask which allows true conditions in the Questionable Data/Signal Event Register to be reported in the summary bit (setting Status Byte Register bit 3 true).

Parameters

Parameter Name	Parameter Type	Range of Values	Default Units
<i>number</i>	Numeric	0 to 65535	0

- Comments**
- **Summary Bit:** If bits 9, 10, 11, or 12 are 1 in the Questionable Data/Signal Enable Register, a transition of Event Register bits 9, 10, 11, or 12 to 1 will cause the associated summary bit to be true.
 - **Maximum Value Entered:** The maximum decimal weighted value used in the Counter/Totalizer module is 7680 (bits 9 - 12 set true).

Example **Set Enable Register Bits 9 through 12 to True**

STAT:QUES:ENAB 7680 *Sets all bits used by the Counter/Totalizer to true.*

:QUESTIONable :ENABLE? **STATus:QUESTIONable:ENABle?** returns the bit value of the Questionable Data/Signal Enable Register.

Comments

- **Output Format:** The command returns a decimal weighted value from 0 to 65535 indicating which bits are set true.

Example **Query the Questionable Data/Signal Enable Register**

STAT:QUES:ENAB? *Queries the Questionable Data/Signal Enable Register.*

:QUESTIONable [:EVENT]? **STATus:QUESTIONable[:EVENT]?** queries the status of the Questionable Data/Signal Event Register.

Comments

- **Information Updated:** The Event Register latches only low to high events from the Condition Register.
- **Output Format:** Returns a decimal weighted value from 0 to 7680 indicating which bits are set true.
- **Reading Contents:** Reading the Event Register by a query will clear its contents.

Example **Read the Questionable Event Register**

STAT:QUES:EVENT? *Queries the Questionable Data/Signal Event Register and clears the contents.*

STAT:QUES? *The short version of the command.*

SYSTEM

The **SYSTEM** command subsystem returns error numbers and messages in the error queue.

Subsystem Syntax SYSTEM
 :ERRor?

:ERRor? **SYSTEM:ERRor?** returns the error numbers and corresponding error messages in the error queue. See Appendix C in this manual for a listing of the error numbers and messages.

Comments

- **Error Numbers/Messages in the Error Queue:** Each error generated by the Counter/Totalizer stores an error number and corresponding error message in the error queue. Each error message can be up to 255 characters long.
- **Clearing the Error Queue:** An error number/message is removed from the queue each time the SYSTEM:ERRor? command is sent. The errors are cleared in a first-in, first-out order. When the queue is empty, each SYSTEM:ERRor? command returns 0, "No error". To clear all error numbers/messages in the queue, execute the *CLS command.
- **Maximum Error Numbers/Messages in the Error Queue:** The queue holds a maximum of 30 error numbers/messages for the Counter/Totalizer. If the queue overflows, the last error number/message in the queue is replaced by -350, "Too many errors". The least recent error numbers/messages remain in the queue and the most recent are discarded.
- ***RST Condition:** *RST *does not* clear the error queue.

Example Reading the Error Queue

SYST:ERR?

Query the error queue, read and print the numbers/messages.

TRIGger

The **TRIGger** command subsystem controls the behavior of the trigger system once it is initiated (see the **INITiate** subsystem earlier in this chapter). The **TRIGger** subsystem can control:

- An immediate software trigger (**TRIGger:IMMEDIATE**).
- The source of the trigger (**TRIGger:SOURce**).

Subsystem Syntax

```
TRIGger  
[:IMMEDIATE]  
:SOURce <source>  
:SOURce?
```

[:IMMEDIATE] **TRIGger[:IMMEDIATE]** causes a trigger cycle to occur immediately provided the trigger system is initiated (see the **INITiate** subsystem earlier in this chapter) and the trigger source is either **TRIGger:SOURce BUS** or **TRIGger:SOURce HOLD**.

Comments

- The **[:IMMEDIATE]** parameter is optional; therefore, **TRIGger:IMMEDIATE** and **TRIGger** have the same effect.
- When the **TRIG:IMM** command is executed, the measurement is stored in mainframe/command module memory. Use **FETCh?** to transfer the measurement to the output buffer.
- The **TRIGger:SOURce BUS** or **TRIGger:SOURce HOLD** command remains in effect after the **TRIG:IMM** command is executed.
- The **INITiate** command begins a measurement cycle. (The **MEASure** and **READ?** commands automatically execute an **INITiate** command.)

Example Sending an Immediate Trigger

```
TRIG:IMMEDIATE Trigger the measurement.
```

:SOURce **TRIGger:SOURce <source>** configures the trigger system to respond to the specified source. The following sources are available:

- **BUS:** Group Execute Trigger (GET) bus command or *TRG common command.
- **HOLD:** Suspend triggering. Only the **TRIGger:IMMEDIATE** command will trigger the Counter/Totalizer.
- **IMMEDIATE:** The trigger system is always true (continuous triggering).

Parameters

Parameter Name	Parameter Type	Range of Values	Default Value
<i>source</i>	Discrete	BUS HOLD IMMEDIATE	IMM

Comments

- The TRIGger:SOURce command only selects the trigger source. The INITiate command enables the trigger system and the trigger source. (The MEASure command automatically executes an INITiate command.)
- TRIGger[:IMMEDIATE] causes a trigger cycle to occur immediately provided the trigger system has been initiated (wait-for-trigger state) by the INITiate command. The trigger source must be TRIGger:SOURce BUS or TRIGger:SOURce HOLD to use TRIGger[:IMMEDIATE].

Note

For measurements that complete (FREQ, PER, TINT, NWID, PWID) TRIG:SOUR BUS can be used so parallel measurements can be made at the same time when the *TRG command or a Group Execute Trigger (GET) is received. Although each measurement may complete at different times, both results will only become available when the longest measurement completes.

-
- The CONFigure and MEASure command subsystems automatically set the trigger source to TRIG:SOUR IMM.
 - **INITiate, MEASure, and READ?** Commands: The INITiate command begins a measurement cycle. The MEAS? and READ? commands cannot be used if the trigger source is BUS or HOLD.
 - ***RST Condition:** TRIG:SOUR IMM

Example Setting the Trigger Source

TRIG:SOUR HOLD

Trigger source is set to hold. The TRIG:IMM command must be executed in order to complete a measurement.

:SOURce? TRIGger:SOURce? returns BUS, HOLD, or IMM, indicating the current trigger source.

Example Querying the Trigger Source

TRIG:SOUR?

Query the Counter/Totalizer to return the current trigger source setting.

IEEE 488.2 Common Commands

The following table lists the IEEE 488.2 Common (*) Commands that can be executed by the Agilent E1332A 4-Channel Counter/Totalizer Module. For more information on Common Commands refer to the *Agilent 75000 Series B Mainframe User's Manual* (Agilent Model Number E1300B/E1301B), the appropriate *Command Module User's Manual*, or the *ANSI/IEEE Standard 488.2-1987*.

Command	Title	Description																		
*IDN?	Identification Query	Returns the identification string of the Counter/Totalizer.																		
*RST	Reset	Resets the Counter/Totalizer hardware and firmware to a specific state (refer to Table 4-1 on page 42 for a list of default conditions).																		
*TST?	Self-Test	Returns 0 if self-test passes or error 1 - 7 if failed: <table border="1" style="margin-left: 40px;"> <thead> <tr> <th>Response</th> <th>Description</th> </tr> </thead> <tbody> <tr> <td>0</td> <td>Self-test passed.</td> </tr> <tr> <td>1</td> <td>Counter did not power-up properly.</td> </tr> <tr> <td>2</td> <td>Problem with digital portion of trigger level.</td> </tr> <tr> <td>3</td> <td>Counter did not properly measure frequency.</td> </tr> <tr> <td>4</td> <td>Counter did not properly measure period.</td> </tr> <tr> <td>5</td> <td>Counter did not properly totalize.</td> </tr> <tr> <td>6</td> <td>Problem with analog portion of trigger level.</td> </tr> <tr> <td>7</td> <td>Counter is not in proper state after being reset.</td> </tr> </tbody> </table>	Response	Description	0	Self-test passed.	1	Counter did not power-up properly.	2	Problem with digital portion of trigger level.	3	Counter did not properly measure frequency.	4	Counter did not properly measure period.	5	Counter did not properly totalize.	6	Problem with analog portion of trigger level.	7	Counter is not in proper state after being reset.
Response	Description																			
0	Self-test passed.																			
1	Counter did not power-up properly.																			
2	Problem with digital portion of trigger level.																			
3	Counter did not properly measure frequency.																			
4	Counter did not properly measure period.																			
5	Counter did not properly totalize.																			
6	Problem with analog portion of trigger level.																			
7	Counter is not in proper state after being reset.																			
*OPC	Operation Complete	Sets the request for OPC flag when all pending operations have completed. Also sets OPC bit in the Standard Event Register.																		
*OPC?	Operation Complete Query	Returns a 1 to the output queue when all pending operations have completed. Used to synchronize between multiple instruments.																		
*WAI	Wait to Complete	Halts execution of commands and queries until the No Operation Pending message is true.																		
*CLS	Clear Status Register	Clears all Event Registers, the request for OPC flag, and all queues (except output queue).																		
*ESE <mask>	Event Status Enable	Used to set the bits in the Event Status Enable Register.																		
*ESE?	Event Status Enable Query	Queries the current contents in the Event Status Enable Register.																		
*ESR?	Event Status Register Query	Queries and clears the contents in the Standard Event Status Register.																		
*SRE <mask>	Service Request Enable	Used to set the Service Request Enable Register bits and corresponding Serial Poll Status Byte Register bits to generate a service request																		
*SRE?	Service Request Enable Query	Queries the current contents in the Service Request Enable Register.																		
*STB?	Read Status Byte Query	Queries the current contents in the Status Byte Register.																		
*TRG	Trigger	Used to trigger a measurement if the TRIGger:SOURce is BUS and the INITiate command has been executed.																		
*RCL <n>	Recall Instrument State	Recalls previously stored Counter/Totalizer module configuration. <n> (0 to 9) is the location in memory where the desired (previously stored) set-up is located.																		
*SAV <n>	Store Instrument State	Stores the present Counter/Totalizer module configuration in memory. Stores all information except DISPlay:MONitor selections and the present contents of reading memory. <n> (0 to 9) is the location in memory where the current set-up is to be stored.																		

Command Quick Reference

The following tables summarize Standard Commands for Programmable Instruments (SCPI) commands and IEEE 488.2 Common (*) Commands for the Agilent E1332A 4-Channel Counter/Totalizer.

SCPI Commands Quick Reference

Command	Description
ABORt	Abort measurement in progress.
CONFigure :FREQuency [<i><range></i> [, <i><resolution></i>]] :NWIDth :PERiod [<i><range></i> [, <i><resolution></i>]] :PWIDth :TINTerval :TOTalize :UDCount	Configure for frequency measurement. Configure for negative pulse width measurement. Configure for period measurement. Configure for positive pulse width measurement. Configure for time interval measurement. Configure for totalize measurement. Configure for up/down count.
CONFigure?	Query the presently selected configuration.
DISPlay :MONitor:CHANnel <i><channel></i> AUTO :MONitor:CHANnel? :MONitor[:STATe] <i><mode></i> :MONitor[:STATe]?	Enters the desired channel number to be viewed when in monitor mode (1 to 4 or AUTO). Returns the presently selected channel number to be viewed when in monitor mode (1 to 4 or AUTO); or the default, minimum, or maximum available channel number. Selects monitor mode to ON (1) or OFF (0). Query state of monitor mode.
FETCH?	Transfers measurement results to the output buffer.
INITiate	Begins a measurement cycle.
INPut :FILTer[:LPASs]:FREQuency <i><frequency MIN MAX DEF></i> :FILTer[:LPASs]:FREQuency? :FILTer[:LPASs][:STATe] <i><state></i> :FILTer[:LPASs][:STATe]? :ISOLate <i><state></i> :ISOLate?	Used to enter digital low-pass input filter frequency. MIN selects 4 Hz, DEF/MAX selects 131.072 kHz. Returns the presently selected digital low-pass input filter frequency; or the default, minimum, or maximum frequencies available. Enables (1 ON) or disables (0 OFF) the digital low-pass input filter. Returns the present digital low-pass input filter selection. Used to select isolated or non-isolated input terminals on all channels. Returns the present input terminal selection.
MEASure :FREQuency? [<i><range></i> [, <i><resolution></i>]] :NWIDth? :PERiod? [<i><range></i> [, <i><resolution></i>]] :PWIDth? :TINTerval?	Perform frequency measurement. Perform negative pulse width measurement. Perform period measurement. Perform positive pulse width measurement. Perform time interval measurement.

SCPI Commands Quick Reference *(continued)*

Command	Description
READ?	Initiate configured measurement and put result in output buffer.
[SENSe:] EVENT:LEVel <number MIN MAX DEF>	Used to set the event level for a specific channel pair. MIN enters -2.56 V, DEF enters 0 V, and MAX enters +2.54 V.
EVENT:LEVel?	Returns the presently selected event level for a specific channel pair; or the default, minimum, or maximum level available.
EVENT:SLOPe <POSitive NEGative>	Used to set the event slope for a specific channel.
EVENT:SLOPe?	Returns the presently selected event slope for a specific channel.
FREQuency:APERture <number MIN MAX DEF>	Used to set aperture time for SENS:FUNC:FREQ configurations. MIN/DEF enters 2 msec, MAX enters 65.536 sec.
FREQuency:APERture? [MIN MAX DEF]	Returns the presently selected aperture time; or the default, minimum, or maximum time available.
FUNCtion:FREQuency	Configure for frequency measurement.
FUNCtion:NWIDth	Configure for negative pulse width measurement.
FUNCtion:PERiod	Configure for period measurement.
FUNCtion:PWIDth	Configure for positive pulse width measurement.
FUNCtion:TINTerval	Configure for time interval measurement.
FUNCtion:TOTalize	Configure for totalize measurement.
FUNCtion:UDCount	Configure for up/down count.
FUNCtion?	Returns the presently selected measurement function.
PERiod:NPERiods <number MIN MAX DEF>	Used to set number of periods for SENS:FUNC:PER configurations. MIN/DEF enters 2, MAX enters 65536.
PERiod:NPERiods? [MIN MAX DEF]	Returns the presently selected number of periods; or the default, minimum, or maximum number available.
TOTalize:GATE:POLarity <polarity>	Used during gated totalize measurements to select the gate channel polarity (accumulate counts when the gate is high (NORM) or low (INV)).
TOTalize:GATE:POLarity?	Returns the presently selected gate polarity.
TOTalize:GATE[:STATe] <state>	Used to enable gating on totalize measurements. 1 ON enables gating, 0 OFF disables gating.
TOTalize:GATE[:STATe]?	Returns whether totalize measurements are being gated.
STATus :QUEStionable:CONDition?	Returns the contents of the Questionable Data/Signal Condition Register.
:QUEStionable:ENABle <number>	Used to set conditions in the Questionable Data/Signal Enable Status Register.
:QUEStionable:ENABle?	Returns the contents of the Questionable Data/Signal Enable Status Register.
:QUEStionable[:EVENTi]?	Returns the contents of the Questionable Data/Signal Event Register.

SCPI Commands Quick Reference *(continued)*

Command	Description
SYSTem :ERRor?	Returns the error number/message in the error queue.
TRIGger [:IMMediate]	Causes a trigger to occur.
:SOURce BUS	Sets trigger source to BUS. Use the *TRG command to trigger.
:SOURce HOLD	Sets the trigger source to hold. Use TRIG:IMM to complete a measurement.
:SOURce IMMEDIATE	Allows measurement to complete after being initiated.
:SOURce?	Returns the presently selected trigger source.

IEEE 488.2 Common Commands Quick Reference

Command	Title	Description																		
*CLS	Clear Status Register	Clears all Event Registers, the request for OPC flag, and all queues (except output queue).																		
*IDN?	Identification Query	Returns the identification string of the Counter/Totalizer.																		
*OPC?	Operation Complete Query	Returns a 1 to the output queue when all pending operations have completed. Used to synchronize between multiple instruments.																		
*RCL <n>	Recall Instrument State	Recalls previously stored Counter/Totalizer module configuration. <n> (0 to 9) is the location in memory where the desired (previously stored) set-up is located.																		
*RST	Reset	Resets the Counter/Totalizer hardware and firmware to a specific state (refer to Table 4-1 on page 42 for a list of default conditions).																		
*SAV <n>	Store Instrument State	Stores the present Counter/Totalizer module configuration in memory. Stores all information except DISPlay:MONitor selections and the present contents of reading memory. <n> (0 to 9) is the location in memory where the current set-up is to be stored.																		
*STB?	Read Status Byte Query	Queries the current contents in the Status Byte Register (bits 3 to 7).																		
*TRG	Bus Trigger	When measurement is initiated and trigger source is TRIG:SOUR BUS, use the *TRG command to trigger a measurement.																		
*TST?	Self-Test Query	Returns one of the following responses (numbers 0 through 7) after completing self-test. <table style="margin-left: auto; margin-right: auto;"> <thead> <tr> <th style="text-align: center;">Response</th> <th style="text-align: center;">Description</th> </tr> </thead> <tbody> <tr> <td style="text-align: center;">0</td> <td>Self-test passed.</td> </tr> <tr> <td style="text-align: center;">1</td> <td>Counter did not power up properly.</td> </tr> <tr> <td style="text-align: center;">2</td> <td>Problem with digital portion of trigger level.</td> </tr> <tr> <td style="text-align: center;">3</td> <td>Counter did not properly measure frequency.</td> </tr> <tr> <td style="text-align: center;">4</td> <td>Counter did not properly measure period.</td> </tr> <tr> <td style="text-align: center;">5</td> <td>Counter did not properly totalize.</td> </tr> <tr> <td style="text-align: center;">6</td> <td>Problem with analog portion of trigger level.</td> </tr> <tr> <td style="text-align: center;">7</td> <td>Counter is not in proper state after being reset.</td> </tr> </tbody> </table>	Response	Description	0	Self-test passed.	1	Counter did not power up properly.	2	Problem with digital portion of trigger level.	3	Counter did not properly measure frequency.	4	Counter did not properly measure period.	5	Counter did not properly totalize.	6	Problem with analog portion of trigger level.	7	Counter is not in proper state after being reset.
Response	Description																			
0	Self-test passed.																			
1	Counter did not power up properly.																			
2	Problem with digital portion of trigger level.																			
3	Counter did not properly measure frequency.																			
4	Counter did not properly measure period.																			
5	Counter did not properly totalize.																			
6	Problem with analog portion of trigger level.																			
7	Counter is not in proper state after being reset.																			

Appendix A

Agilent E1332A Specifications

Functions:

Frequency Measurement

Channels 1 & 3 measure frequency up to 4 MHz.
Select the resolution directly in Hz or the gate time from 2 msec to 65.5 sec in 16 binary steps.

Minimum Pulse Width: 125 nsec

Resolution: 1/Gate time

Accuracy: \pm resolution \pm timebase error \pm trigger noise error

Period Average Measurement

Channels 1 & 3 average 2^N periods of an input signal.
Select the resolution directly in seconds or the number of periods to be averaged.

Period Range 1 μ sec - 858 sec

Minimum Pulse Width: 125 nsec

Range of N: 1 to 16

Resolution: $1 / (5 \times 10^6 \times 2^N)$ sec

Accuracy: \pm resolution \pm timebase error \pm trigger noise error

Pulse Width Measurement

Channels 2 & 4 measure pulse width (positive or negative) of an input signal.

Minimum Pulse Width: 500 nsec

Maximum Pulse Width: 858 sec

Resolution: 200 nsec

Accuracy: \pm resolution \pm timebase error \pm trigger noise error

Time Interval Measurement

Measure the time interval between transitions from channel 1 to channel 2 or from channel 3 to channel 4. Select the rising or falling edge via software commands.

Minimum Interval: 500 nsec

Maximum Interval: 858 sec

Resolution: 200 nsec

Accuracy: \pm resolution \pm timebase error \pm trigger noise error

Totalizing

Count the number of transitions (rising or falling edge) on channels 1, 2, 3 & 4.

Minimum Pulse Width: 125 nsec

Range: 1 to $2^{32} - 1$ Counts

Gated Totalizing

Count the number of transitions (rising or falling edges) on channels 1 & 3. Channel 2 is used as a gate for channel 1. Channel 4 is used for channel 3. The polarity of the gate is programmable.

Minimum Pulse Width: 125 nsec

Range: 1 to $2^{16} - 1$ Counts

Up/Down Counting

Channels 1-2 and channels 3-4 form the up/down pairs. The count on channel 2 (4) is subtracted from that on channel 1 (3) and the result is given.

Minimum Pulse Width: 125 nsec

Range: $\pm (2^{31} - 1)$

Common Specifications:

Frequency Range: 0.002 Hz to 4 MHz (input filter is OFF)	Trigger Level Accuracy: Low Range: ± (10% level + 20 mV)	Module Size/Device Type: B, register-based
Pass Frequency of Input Digital Filter: 4 Hz to 131 kHz in 16 binary steps	High Range: ± (10% level + 200 mV)	Connectors Used: P1
Maximum Screw Terminal Wire Size: 16 AWG	Input Level Sensitivity: Low Input Range DC to 2 MHz: 25 mV 2 MHz to 4 MHz: 50 mV	No. Slots: 1
Timebase Frequency: 10 MHz	High Input Range: DC to 100 kHz: 250 mV 100 kHz to 1 MHz: 500 mV 1 MHz to 2.5 MHz: 1 V 2.5 MHz to 3.5 MHz: 2 V	VXIbus Interface Capability: Interrupter, A16
Accuracy: 2 ppm	Dynamic Range: Low Input Range DC to 2 MHz: 43 dB 2 MHz to 4 MHz: 37 dB	Interrupt Level: 1 - 7, selectable
Aging Rate: 2 ppm/year	High Input Range: DC to 100 kHz: 35 dB 100 kHz to 1 MHz: 29 dB 1 MHz to 2.5 MHz: 23 dB 2.5 MHz to 3.5 MHz: 17 dB	Power Requirements: Voltage: +5 +12 -12 Peak module current, IPM (A:) 0.50 0.03 0.02 Dynamic module current, IDM (A:) 0.01 0.01 0.01
Temperature Drift: 5 ppm (0° to 50° C)	Isolated Input: Vin (High): >4.2 V Vin (Low): <1 V Iin (High): >6.3 mA Iin (Low): <250 µA	Watts/Slot: 3.0
Trigger Noise Error (RMS): $\frac{\sqrt{[(200 \mu V^2) + (E_n)^2]}}{\text{Input Slew Rate at Trigger Point (}\mu V/sec)}$	Isolation: 170 V Peak (Channel to channel, channel to chassis)	Cooling/Slot: 0.05 mm H ₂ O @0.25 liter/sec
En: Noise on input signal for 5 MHz bandwidth		Humidity: 65%, 0° to 40° C
Non-isolated Input		Operating Temperature: 0° to 55° C
Input Impedance (typical): 100 kΩ shunted by 80 pF		Storage Temperature: -40° to 75° C
Input Range (jumper selectable): Low Range: ±5 V High Range: ±42 V		EMC, RFI, Safety: meets FTZ 1046/1984, CSA 556B, IEC 348, UL 1244
Trigger Level:		Net Weight (kg): 0.6
Low Input Range: -2.56 to 2.54 V in 20 mV step		
High Input Range: -25.6 to 25.4 V in 0.2 V step		

Agilent E1332A Register-Based Programming

Using This Appendix

The Agilent E1332A 4-Channel Counter/Totalizer module is a register-based device. This appendix contains the following register-based programming information.

- About Register-Based Programming Page 113
- Addressing the Registers Page 113
- Register Definitions Page 116
- Register Descriptions Page 117
- Interrupt Requests Page 121
- Command and Parameter Summary Page 122
- Register Programming Procedure Page 130
- Register Programming Flowchart Page 134
- Embedded Controller Example Programs Page 135
- Register Programmed Pulse Width Page 141

About Register-Based Programming

The 4-Channel Counter/Totalizer module is a register-based module that allows you to do reads and writes directly to the Counter/Totalizer registers. When SCPI commands (Standard Commands for Programmable Instruments) are used, the VXI Series C Agilent E1405A/06A Command Module or VXI Series B Agilent E1300B/E1301B Mainframe parses the command and writes to the appropriate registers on the Counter/Totalizer. Parsing is eliminated with register-based programming, increasing measurement throughput speed. Register-based programming allows the use of an embedded controller which can access the VXIbus directly. Additionally, the command module can be removed from a C-size mainframe if the slot 0 resource manager and the computer interface (GPIB) are provided by another device.

Addressing the Registers

Each register-based device (up to 256 devices) is allocated 64 register addresses. The Agilent E1332A Counter/Totalizer uses six of the 64 possible registers. Register addresses for register-based devices are located in the top 25% of the VXI A16 address space as defined by the VXIbus specification (a C000₁₆ offset is present in the module address).

Figure B-1 shows the Counter/Totalizer register address location within A16 when the command module or mainframe address space is not used. It also shows the location of A16 address space in the Agilent

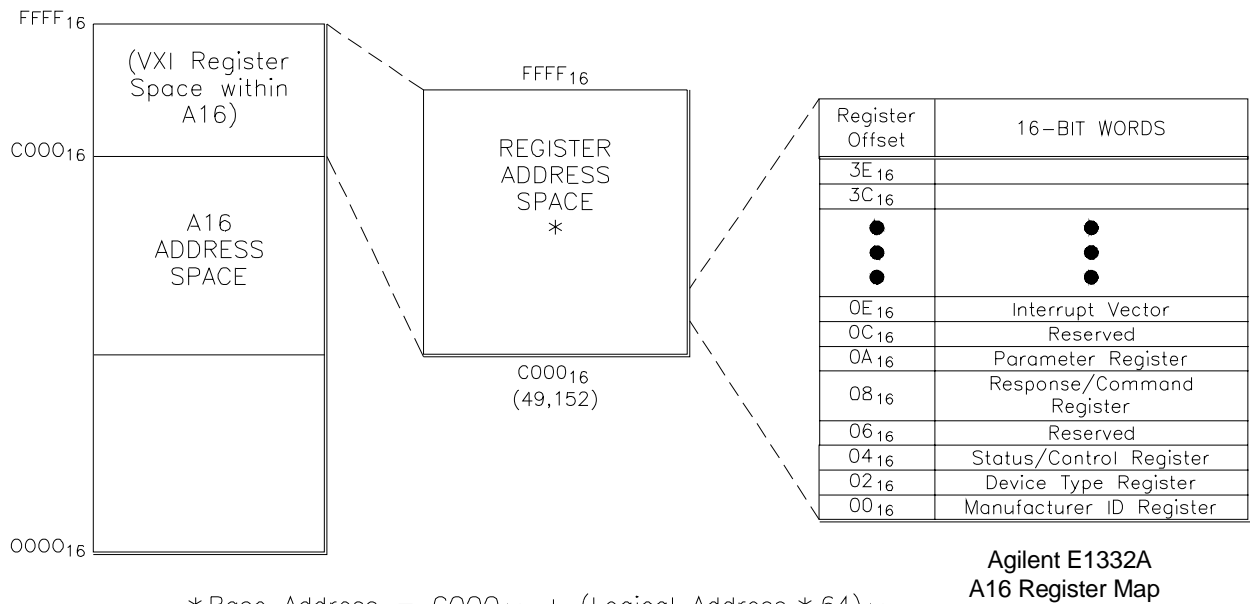

$$* \text{Base Address} = \text{C000}_{16} + (\text{Logical Address} * 64)_{16}$$

$$\text{or}$$

$$49,152 + (\text{Logical Address} * 64)_{10}$$

$$\text{Register Address} = \text{Base address} + \text{Register Offset}$$

A24 Address Space Internal to Mainframe (Series B E1300A)
or Command Module (Series C E1405A)

Figure B-1. Counter/Totalizer Registers within A16 Address Space

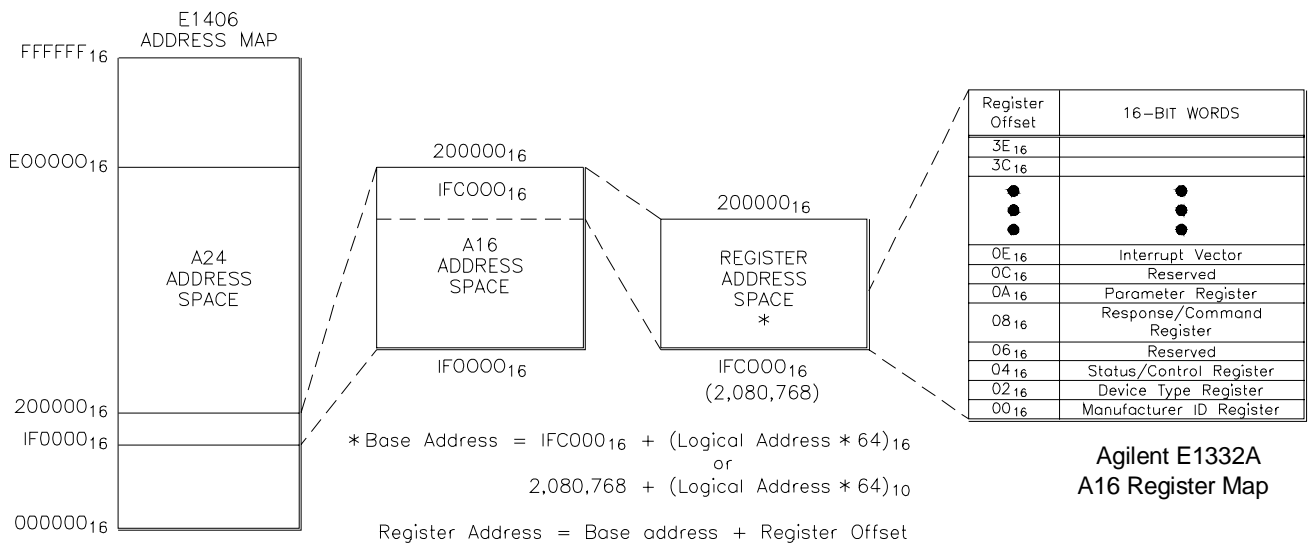

$$* \text{Base Address} = \text{IFC000}_{16} + (\text{Logical Address} * 64)_{16}$$

$$\text{or}$$

$$2,080,768 + (\text{Logical Address} * 64)_{10}$$

$$\text{Register Address} = \text{Base address} + \text{Register Offset}$$

Figure B-2. Mainframe/Command Module A16 Address Space

The Base Address

To read or write to specific registers, specify the register address either in hexadecimal or decimal. This address consists of a base address plus a register offset. The base address depends on whether the A16 address space is outside or inside the Series C Agilent E1405A/06A Command Module or Series B Agilent E1300B/E1301B Mainframe.

A16 Address Space Outside the Command Module or Mainframe

When the command module or mainframe is not part of your VXIbus system, (Figure B-1), the Agilent E1332A base address is computed as:

hexadecimal	decimal
$C000_{16} + (LADDR * 64)_{16}$	$49,152 + (LADDR * 64)$

where $C000_{16}$ (49,152) is the starting location of the register addresses, LADDR is the counter's logical address, and 64 is the number of address bytes per. For example, the counter's factory set logical address is 48. If this address is not changed, the counter will have a base address of:

hexadecimal	decimal
$C000_{16} + (48 * 64)_{16}$	$49,152 + (48 * 64)$
$C000_{16} + C00_{16} = CC00_{16}$	$49,152 + 3,072 = 52,224$

A16 Address Space Inside the Command Module or Mainframe

When the A16 address space is inside the command module or mainframe (Figure B-2), the Agilent E1332A base address is computed as:

hexadecimal	decimal
$1FC000_{16} + (LADDR * 64)_{16}$	$2,080,768 + (LADDR * 64)$

where $1FC000_{16}$ (2,080,768) is the starting location of the register addresses, LADDR is the counter's logical address, and 64 is the number of address bytes per module. For example, the Counter/Totalizer's factory set address is 48. If this address is not changed, the counter has a base address of:

hexadecimal	decimal
$1FC000_{16} + (48 * 64)_{16}$	$2,080,768 + (48 * 64)$
$1FC000_{16} + C00_{16} = 1FCC00_{16}$	$2,080,768 + 3,072 = 2,083,840$

Register Offset The register offset is the register's location in the block of 64 address bytes (see Figure B-1). For example, the Agilent E1332A Command Register has an offset of 08₁₆. When writing a command to this register, this offset is added to the base address to form the register address:

Address Space	Hexadecimal Register Address	Decimal Register Address
Outside the command module or mainframe	CC00 ₁₆ + 08 ₁₆ = CC08 ₁₆	52,224 + 8 = 52,232
Inside the command module or mainframe	1FCC00 ₁₆ + 08 ₁₆ = 1FCC08 ₁₆	2,083,840 + 8 = 2,083,848

Register Definitions

You can program the Agilent E1332A Counter/Totalizer using its hardware registers. *The procedures for reading or writing to a register depend on your operating system and programming language.* Whatever the access method, you will need to identify each register by its address. These addresses are given in Table B-1.

Table B-1. Counter/Totalizer Addressable Registers

Register Offset	READ Registers	WRITE Registers
00 ₁₆	Manufacturer ID Register	undefined
02 ₁₆	Device Type Register	undefined
04 ₁₆	Status Register	Control Register
06 ₁₆	reserved	reserved
08 ₁₆	Response Register	Command Register
0A ₁₆	undefined	Parameter Register
0C ₁₆	reserved	reserved
0E ₁₆	Interrupt vector	undefined

The module is a register-based slave/interrupter device, supporting VME D16, D8(O), and D8(OE) transfers. The interrupt protocol supported is "release on Register access" - an interrupt is cleared only by servicing the cause of the interrupt (generally by reading or writing a byte of data). Interrupts are not cleared by a VXibus interrupt acknowledge cycle.

Register Descriptions

The following pages detail register descriptions for the Agilent E1332A 4-Channel Counter/Totalizer module.

Manufacturer ID Register

The Manufacturer Identification Register is a read-only register at address 00₁₆. Reading this register returns FFF₁₆ which indicates the manufacturer is Agilent Technologies and that the module is an A16 register-based device.

base + 00 ₁₆	15	14	13	12	11	10	9	8	7	6	5	4	3	2	1	0
WRITE	Undefined															
READ	Manufacturer ID (all 1's = FFFF ₁₆ = Agilent Technologies A16 register-based)															

(00₁₆ = register offset; see "Addressing the Registers" on page 113)

Device Type Register

The Device Type Register is a read-only register accessed at address 02₁₆. Reading this register returns the Counter/Totalizer Module Identification of 60₁₆.

base + 02 ₁₆	15	14	13	12	11	10	9	8	7	6	5	4	3	2	1	0
WRITE	Undefined															
READ	1	1	1	1	1	1	1	1	0	1	1	0	0	0	0	0

Status (READ)/Control (WRITE) Register

The module Status/Control Register is a read/write register accessed at address 04₁₆. The following table shows the register bit patterns.

base + 04 ₁₆	15	14	13	12	11	10	9	8	7	6	5	4	3	2	1	0
WRITE*	Ignored								X	X	X	X	X	X	SYS/FAIL	RESET
READ	1	1	1	1	1	1	1	1	DON	X	X	X	X	TST	QRR	RDY

*Refer to the following table for an explanation of the bits.

Three bits (0, 1, and 7) of the eight bit Status Register (register 04₁₆) provide information on the operational status of the Counter/Totalizer.

Bit No.	Bit Mnemonic	Comments
0	RDY	A one (1) indicates the counter's data buffer is empty and that data may be written to the Command Register (08 ₁₆) or the Parameter Register (0A ₁₆).
Bit 0 must be high (1) for bit 7 to be valid.		
7	DON	A one (1) indicates that the previous command and parameter have been processed. Writing to the Command Register (08 ₁₆) when this bit is zero (0) may abort the command in progress.
Bit 7 must be high (1) for bit 1 to be valid.		
1	QRR	A one (1) in this field indicates that the Response Register (08 ₁₆) is loaded and ready to be read.
2	TST	A one (1) indicates Self Test passed, a zero (0) indicates the self test is in progress or has failed.

You can write to the Control Register to disable the Counter/Totalizer from driving the SYSFAIL line and then reset the Counter. Bit 1 controls inhibiting system fail and bit 0 controls the reset. Both of these bits are HIGH true. The counter is held in the reset mode as long as bit 0 is held high. Normal operation begins when this bit is returned to the low state. The following causes a reset:

1. Write 02₁₆ to the Control Register to inhibit the SYSFAIL line.
2. Write 03₁₆ to the Control Register to keep SYSFAIL inhibited and initiate the reset mode (reset starts when bit 0 returns to low).
3. Wait 10 microseconds.
4. Write 02₁₆ to the Control Register to set the RESET bit low and start the reset.
5. When bit 2 (TST) of the Status Register is high, the counter has passed self-test.
6. Write 00₁₆ to the Control Register to enable the drive of the SYSFAIL line.

NOTE: It is recommended you reset the Counter/Totalizer using register command 15.

Command (WRITE)/ Response (READ) Register

Register 08₁₆ is the Query Response Register. This register contains the measurement data obtained by using the Read Channel command (command 14) or the response from the Read Status command (command 13).

base + 08 ₁₆	15	14	13	12	11	10	9	8	7	6	5	4	3	2	1	0
WRITE*	1	1	1	1	1	1	1	1	1, 2, 3, 4, 5, 6, 7, 8, 9, 10, 12, 13, 14, or 15							
READ	ignored								data bits for measurement or status query							

*Refer to “Register Command 13” or to “Computing the Answer” later in this appendix for response information.

There are fourteen register-based commands used for setting up the input, making measurements, reading the measurement data, and reading the state of the Counter/Totalizer (what function it is programmed for, what the input filter is set at, etc.). Each command must be followed by a parameter (or 3 parameters for command 11) which completes the command. Even the reset command (command 15) must be followed by a parameter to complete the command although this parameter does not provide any information needed to reset the Counter/Totalizer.

Command List

Command	Description	Required Parameter
1	Event level 1 and 2	Sets event level for channels 1 and 2.
2	Event level 3 and 4	Sets event level for channels 3 and 4.
3	Source and Filter	Sets input and filter parameters.
4	Measure frequency	Sets channel, polarity, and gate time.
5	Measure period	Sets channel, polarity, and number of cycles.
6	Measure time interval	Sets channel numbers., start, and stop edges.
7	Measure pulse width	Sets channel number and polarity.
8	Gated count	Sets channel number, polarity, and gate.
9	Up Down count	Sets channel number and polarity.
10	Totalize	Sets channel number and polarity.
11	Modulo count	Sets channel number, polarity, and preset.
13	Read status	Specifies the type of status request.
14	Read channel	Sets the channel that will be read.
15	Reset	Only needed to complete the reset.

Parameter Register

Register 0A₁₆ is the Command Parameter Register. Commands are not processed until the required number of parameters are received. A command is ignored if a new command is sent before the required number of parameters are sent for the first command. If a second command is sent before the first command completes execution, the first command may only partially complete.

base + 0A ₁₆	15	14	13	12	11	10	9	8	7	6	5	4	3	2	1	0
WRITE	1	1	1	1	1	1	1	1	Required parameter(s)							
READ	Ignored															

Interrupt Vector Register

Register 0E₁₆ is the Interrupt Vector Register. Functions that complete a measurement set a bit in the Interrupt Vector Register to indicate which function completed.

base + 0E ₁₆	15	14	13	12	11	10	9	8	7	6	5	4	3	2	1	0
Write	Undefined															
Read*	TI 3-4 PW 4	TI 1-2 PW 2	Freq3	Freq1	Mod4	Mod3 PER3	Mod2	Mod1 PER1	Bits 7 - 0 are ignored							

Bits 8, 9, 10, and 11 indicate counter roll over for the modulo count function.
 Bits 8 and 10 indicate period complete when channel 1 or 3 make a period measurement.
 Bits 14 and 15 indicate pulse width complete when channel 2 or 4 make a pulse width measurement.

Either bit 8 through 15 is set **LOW** when the function associated with the bit has completed a measurement or the modulo count has rolled over. The bit-function association is as follows:

Bit	Channel	Function Causing the Interrupt
8	Channel 1	Modulo count rolled over (Modulo count function)
		Period (PER function) complete
9	Channel 2	Modulo count rolled over
10	Channel 3	Modulo count rolled over (Modulo count function)
		Period (PER function) complete
11	Channel 4	Modulo count rolled
12	Channel 1	Frequency (FREQ function) complete
13	Channel 3	Frequency (FREQ function) complete
14	Channel 1-to-2	Time interval (TINT function) complete
	Channel 2	Pulse width complete
15	Channel 3-to-4	Time interval (TINT function) complete
	Channel 4	Pulse width complete

These functions pull the interrupt line. You then read the interrupt vector to see which function has completed or rolled over and then read the measurement data.

Interrupt Requests

The Counter/Totalizer generates an interrupt request by pulling the specific interrupt line set by the IRQ jumpers (IRQ 1 through 7). The Counter/Totalizer generates an interrupt when the counter rolls over or a measurement is complete (a response interrupt). An interrupt handler within the mainframe services the interrupt. Actual servicing of the interrupt begins when the handler obtains the data transfer bus because the logical address and status of the module is read by the handler over this bus.

The handler drives the interrupt acknowledge line (IACK*) low and broadcasts a 3-bit interrupt acknowledge code over the three least significant address lines. The slot 0 module (controller) generates an interrupt acknowledge through a daisy-chained line to all modules in the frame one at a time. If a module has generated an interrupt, it reads the lower three address lines to verify the code matches the level of interrupt it generated (for example IRQ1). If the interrupt code matches, the interrupt handler reads a 16-bit word from the data transfer bus containing the module's logical address (bits 0-7) and the status or cause of the interrupt (bits 8-15). The E1332A Counter/Totalizer reports an event or a cause which is a roll over of the counter or a measurement complete and is specified by the Interrupt Vector Register shown above (some other modules may report the status byte).

This method of servicing interrupt requests allows you to identify the interrupting module and which function or process completed/rolled over.

Command and Parameter Summary

Register Command 1 Command 1 sets the event level for channels 1 and 2. The event level can be set to 256 different levels in 20 millivolt steps from -2.56V to +2.54V using the parameter.

Parameter This command requires one (1) parameter (a two's complement number) to set the level. There are 256 choices from 00₁₆ to FF₁₆.

FF₁₆ = +2.54, FE₁₆ = +2.52...
 81₁₆ = +0.02, 80₁₆ = 0.00, 7F₁₆ = -0.02...
 01₁₆ = -2.54, 00₁₆ = -2.56

Register Command 2 Command 2 sets the event level for channels 3 and 4. The event level can be set to 256 different levels in 20 millivolt steps from -2.56V to +2.54V using the parameter.

Parameter This command requires one (1) parameter (a two's complement number) to set the level. There are 256 choices from 00₁₆ through FF₁₆.

FF₁₆ = +2.54, FE₁₆ = +2.52...
 81₁₆ = +0.02, 80₁₆ = 0.00, 7F₁₆ = 0.02...
 01₁₆ = -2.54, 00₁₆ = -2.56

Register Command 3 Command 3 sets the input and filter parameters. Bits 0, 1, 2, and 3 of the parameter byte define the digital low-pass filter constant. Bit 4 specifies filter on or off and bit 5 specifies whether the input is the direct or isolated inputs. Filter off overrides the filter constant.

Parameter

	BIT NUMBER							
	7	6	5	4	3	2	1	0
0	X	X	Direct	OFF	Bits 0, 1, 2, and 3 = filter constant in 16 binary steps; 0000 = 131 kHz to 1111 = 4 Hz			
1	X	X	Isolated	ON				

Register Command 4

Command 4 performs a frequency measurement. Requires one parameter which specifies the channel for the measurement, polarity, and the gate time. Bits 0, 1, 2, and 3 specify the gate time. Bit 4 specifies the polarity and bit 5 specifies either channel 1 or channel 3.

Parameter

BIT NUMBER							
7	6	5	4	3	2	1	0
X	X	Channel number: 0 = Ch. 1 1 = Ch. 3	Polarity: 0 = negative 1 = positive	Gate time (16 steps): 0000 = 2 msec 0001 = 4 msec . 1110 = 32768 msec 1111 = 65536 msec			

Register Command 5

Command 5 performs a period measurement. This command requires one parameter which specifies which channel to measure on, the polarity, and the number of cycles to average for the measurement. Bits 0, 1, 2, and 3 specify the number of cycles. Bit 4 specifies polarity, and bit 5 specifies either channel 1 or channel 3.

Parameter

BIT NUMBER							
7	6	5	4	3	2	1	0
X	X	Channel number: 0 = Ch. 1 1 = Ch. 3	Polarity: 0 = negative 1 = positive	Number of cycles (16 steps): 0000 = 2 cycles 0001 = 4 cycles - 1110 = 32768 cycles 1111 = 65536 cycles			

Register Command 6

Command 6 makes a time interval measurement. The parameter contains one bit (bit 0) which specifies whether the measurement is between channels 1 and 2 or between channels 3 and 4. Bit 1 specifies the polarity of the start edge and bit 2 specifies the stop edge.



Parameter

	BIT NUMBER							
	7	6	5	4	3	2	1	0
0	X	X	X	X	X	Stop	Start	Channel 1-to-2
1	X	X	X	X	X	Stop	Start	Channel 3-to-4

Register Command 7

Command 7 makes a pulse width measurement. A single parameter contains a bit (bit 0) to indicate which channel makes the measurement and a bit (bit 1) to indicate the polarity of the start edge.

Parameter

	BIT NUMBER							
	7	6	5	4	3	2	1	0
0	X	X	X	X	X	X	Start 	Channel 2
1	X	X	X	X	X	X	Start 	Channel 4

Register Command 8



Command 8 allows you to do a gated count. A single parameter uses three bits to specify which channel counts and which gates (bit 0), the polarity of the gate level (bit 1), and the polarity of the counted edges (bit 2).

16-Bit Gated Count

Gated count only provides a 16-bit count versus 32-bits. Six bytes must still be read when reading the channel. The first byte contains the overflow bit at bit 7; all other bits are 0. For example, if there is an overflow, the byte returns 80_{16} , otherwise it returns 00_{16} . Gated count does not generate an interrupt on overflow. Bytes 2 and 3 are driven to 00_{16} . Bytes 4 and 5 contain the 16-bit gated count. Byte 6 is a fixed exponent and always is 80_{16} .

The gated count can be read at any time to obtain a cumulative count. This will not reset the counter. The counter is reset only when another command 8 and its parameter is executed.





Parameter

	BIT NUMBER							
	7	6	5	4	3	2	1	0
0	X	X	X	X	X	Count 	Gate level low	Channel 2 gates Channel 1
1	X	X	X	X	X	Count 	Gate level high	Channel 4 gates Channel 3

Register Command 9

Command 9 allows you to up down count. A single parameter uses three bits to specify which channels to count on (bit 0), the polarity of the down counted edges (bit 1), and the polarity of the up counted edges (bit 2).

Parameter

	BIT NUMBER							
	7	6	5	4	3	2	1	0
0	X	X	X	X	X	UP Count 	DOWN Count 	Channel 1 and Channel 2
1	X	X	X	X	X	UP Count 	DOWN Count 	Channel 3 and Channel 4



Register Command 10

Command 10 totalizes events. A single parameter is sent to specify which channel is to totalize and the polarity of the counted edges. Bit 0 specifies the polarity of the counted edges. Bits 1 and 2 specify the channel to count on.

Totalize Count

The accumulated count can be read repeatedly. The counter is not reset when the channel is read so repetitive reading will give the cumulative total. If more than 2^{32} events are counted, the overflow bit is set on the first overflow. The counter rolls over and continues the count but the overflow bit will be set following the first overflow until the channel is reprogrammed. The overflow bit is bit 7 of the first data byte; all other bits of the first byte are 0 e.g. if overflow occurs, the byte returns 80_{16} , otherwise 00_{16} is returned.

Parameter

	BIT NUMBER							
	7	6	5	4	3	2	1	0
0	X	X	X	X	X	Channel number: 00 = Channel 1 01 = Channel 2 10 = Channel 3 11 = Channel 4		Count edge 
1	X	X	X	X	X			Count edge 

Register Command 11

Command 11 allows you to modulo count. **Modulo counting can be executed using register-based programming but unlike the other functions, it cannot be performed using SCPI commands.** Modulo count requires three parameters. The first parameter specifies the polarity of the counted edges (bit 0) and which channel to count on (bits 1 and 2). The next two parameters contain the 16-bit value of the counter preset. The first of these two is the most significant byte.

Modulo Count Interrupt



An interrupt is generated each time the count rolls over if the previous modulo interrupt on the channel has been cleared. If the first interrupt is not cleared, subsequent interrupts cannot be detected.

Reading the Modulo Count

The counter channel can be read at any time without resetting the counter. The modulo count is a 16-bit count versus 32-bits. The first byte contains the overflow bit at bit 7; all other bits are 0. In other words, if an overflow occurs, the byte is 80_{16} , otherwise it is 00_{16} .

Bytes 2 and 3 (upper 16-bits) indicate the number of times the lower 16-bits (bytes 4 and 5 containing the count) has rolled over since the command started. Bytes 4 and 5 contain the current count using the preset modulo.

Parameters **First parameter:**

	BIT NUMBER							
	7	6	5	4	3	2	1	0
0	X	X	X	X	X	Channel number: 00 = Channel 1 01 = Channel 2 10 = Channel 3 11 = Channel 4		Count edge 
1	X	X	X	X	X			Count edge 

Second parameter: Specifies the most significant byte of the value for presetting the counter.

Third parameter: Specifies the least significant byte of the value for presetting the counter.

Register Command 13

Command 13 reads the status of the counter. The requested information is entered into the Response Register 08₁₆. A single parameter specifies the type of status request defining the information that is returned.

Parameter	Type of Status Request/Information Returned
0	Polarities, isolation, and filter enabled/disabled
1	Function of counter 1
2	Function of counter 2
3	Function of counter 3
4	Function of counter 4
5	Level for channels 1 and 2
6	Level for channels 3 and 4
7	Filter constant
8	LSB for modulo count on channel 1
9	MSB for modulo count on channel 1
10	LSB for modulo count on channel 2
11	MSB for modulo count on channel 2
12	LSB for modulo count on channel 3
13	MSB for modulo count on channel 3
14	LSB for modulo count on channel 4
15	MSB for modulo count on channel 4

Parameter 0

	BIT NUMBER							
	7	6	5	4	3	2	1	0
	X	X	INPUT (dir/iso)	FILTER (out/in)	Chan. 4 polarity	Chan. 3 polarity	Chan. 2 polarity	Chan. 1 polarity
0	X	X	Direct	Disabled				
1	X	X	Isolated	Enabled				

For gated count, a 1 indicates gate level is high, 0 indicates gate level is low.

Parameter 1 through 4

The four MSB of the response indicate the function. The four LSB of the response indicate the gate time or number of cycles.

4 Most Significant Bits	4 Least Significant Bits
0000 = Frequency	0000 = 2 ms to 1111 = 65.536 sec gate time
0010 = Period	0000 = 2 cycles to 1111 = 65536 cycles
0011 = Time interval	Driven to 0000
0100 = Pulse width	Driven to 0000
0101 = Totalize	Driven to 0000
0110 = Gated count	Driven to 0000
0111 = Modulo counting	Driven to 0000
1000 = Up down counting	Driven to 0000
1001 = Not programmed	Driven to 0000

If a two-channel function is queried, channels 1 and 3 return the correct result. Channels 2 and 4 will always return a "Not programmed" response (10010000).

Parameters 5 and 6

Returns the event level set by command 1 or 2 as a two's compliment number. See commands 1 and 2 for definition of returned value.

Parameter 7

BIT NUMBER							
7	6	5	4	3	2	1	0
X	X	X	X	0000 = 131 kHz . . . 1111 = 4 Hz			

Parameters 8 through 15

Returns the modulo counter preset value. Two parameters are needed to query each channel for the LSB and MSB or the preset count.

Register Command 14

Command 14 reads a single channel and the result depends on what that channel had been programmed to do. A single parameter, using bits 0 and 1, specifies the channel to be read.

- The result is returned in 6 bytes. The first 5 bytes are the mantissa. The 6th byte is the exponent. The result must be constructed from these six bytes.
- For totalize, modulo counting, up/down counting, and gated counting, the exponent is zero (80₁₆).
- For frequency, the exponent will tell how many bits to shift to give an answer in Hertz.
- For time interval, pulse width, or period, the exponent will tell how many bits to shift to give the result in seconds.
- For overflow, bit 7 of the first byte will be 1.
- For a channel that is not programmed, the result will be all 1's.
- For an invalid request, the result will be all 1's.
- When measuring pulse width connect to and program channel 2 or 4, but when you read the data it comes from channels 1 and 3.

Parameter

BIT NUMBER							
7	6	5	4	3	2	1	0
X	X	X	X	X	X	00 = Channel 1 01 = Channel 2 10 = Channel 3 11 = Channel 4	

Register Command 15

Command 15 resets the counter to the power-on condition. The command must include a parameter.

Parameter

What is sent for the parameter is not important. The parameter for command 15 can be anything (for example send 0). The reset action starts when the parameter is received.

Register Programming Procedure

The procedure described below shows the STATUS bit states required before writing to or reading from the registers. The procedure shows the sequence used to execute a command/parameter and how to detect when a measurement is complete followed by reading back the data.

1. Check the STATUS byte bits 0 and 7 to verify that the input buffer is empty and the previous command will not be aborted.
 - Check that STATUS bit 0 is high (command/parameter ready bit) to verify that the input buffer is empty and the Command Register can be written to.
 - Check that STATUS bit 7 is high (DONE) which indicates the module has processed the previous command.
 - If you want to abort a command before the parameter is sent or abort a command in process, you can simply write a new command to the Command Register. The first command will be aborted and the command sent last is processed and executed.
 - To keep from losing measurement data, you must retrieve the data from the previous command execution before sending a new command. Sending a command destroys previous data from all channels with the exception of the totalize function if the previous command was also totalize. For example, if channel 1 is programmed for totalize, subsequently programming channel 2 for totalize will not destroy the cumulative counting of channel 1 or vice versa.
2. SEND COMMAND TO COMMAND REGISTER. Write the opcode to the Command Register (Register 08₁₆).
 - Check that STATUS bit 0 is high (command/parameter ready). The input buffer must be empty for the parameter to be recognized.
3. SEND PARAMETER TO PARAMETER REGISTER. Write parameter to Parameter Register (Register 0A₁₆).
 - All commands are executed after the parameter is accepted.
 - For a command that does not return data e.g., set trigger level, set input conditioning, or reset, the command is executed and no further programming for the command is required. Continue with this procedure for commands that return data.
 - IF THE COMMAND SENT IS A TYPE THAT RETURNS DATA AND INTERRUPTS WHEN THE MEASUREMENT IS COMPLETE (frequency, period, modulo count, time interval), CONTINUE WITH STEP 4. IF THE COMMAND RETURNS DATA BUT DOES NOT INTERRUPT (totalize, up/down count, gated count, or read status), CONTINUE WITH STEPS 12 or 13.

4. WAIT FOR INTERRUPT. Wait for the counter to pull the interrupt line. See the following note!

Note

Do not poll the Interrupt Vector Register (0E₁₆) to detect measurement complete because this may cause noise on the card during the measurement process.

5. CHECK WHICH PROCESS HAS COMPLETED. Read register 0E₁₆ (interrupt vector) to determine which process completed (check the bit associated with function performed).
 - Check that STATUS bit 0 is high (command/parameter ready).
6. READ THE CHANNEL THAT MADE THE MEASUREMENT. Write opcode 14 (READ CHANNEL) to Command Register 08₁₆.
 - Check that STATUS bit 0 is high (command/parameter ready).
7. SEND PARAMETER TO TELL WHICH CHANNEL TO READ. Write to Parameter Register 0A₁₆ to tell which channel to read.
 - Check that STATUS bit 0 is high (command/parameter ready) and bit 7 is high (DONE). Bit 7 indicates the command has been processed. Bit zero (0) must be true for bit 7 to be valid.
8. CHECK THAT THE QUERY RESPONSE REGISTER HAS BEEN LOADED BY DOING THE FOLLOWING:
 - Check that STATUS bit 1 is high for Query Response Register ready (indicates data has been put into the Query Response Register and can be read).
9. READ THE DATA FROM THE COUNTER. The measurement or count is in six (6) bytes so Response Register 08₁₆ must be read six times.
 - a) Read the Query Response Register (register 08₁₆)
 - b) Enter the data (data is in the lower 8 bits)
 - c) BINAND data with 255 (masks bits 8 and above)
10. REPEAT STEP 8 AND 9 FIVE MORE TIMES (measurement is in 6 bytes and you must verify that the Query Response Register has been loaded for each byte).
11. CALCULATE THE ANSWER. See the following section “Computing the Answer”.
 - Steps 12 and 13 are for commands that return data but do not pull the interrupt when the command completes as do measurement commands 4, 5, 6, 7, 8, and 11.
12. IF THE COMMAND EXECUTED IS "TOTALIZE", the current total (six bytes) can be read anytime by executing steps 6 - 11.

13. IF THE COMMAND IS "READ STATUS", a single byte is returned by executing steps 6 through 8 and reading one data byte.

Computing the Answer

Enter six words of data (the upper byte of each word is always ignored) from the Query Response Register (A(1), A(2), A(3), A(4), A(5), and A(6)). The lower byte of the first five words are the mantissa of the data, the lower byte of the sixth word, A(6), is the exponent of the data.

Checking For Overflow

Bit 7 of the first word, A(1), when set high after a measurement or count, tells you if the counter has overflowed. For a measurement such as frequency, period, time interval, or ratio, the measurement data is invalid. If the counter is totalizing events (totalize function), bit 7 is set high after the counter rolls over the first time (exceeds a count of 2^{36}). The count from the other bits is still valid but you must keep track of the number of times the counter rolls over to keep an accurate cumulative count. Bit 7 remains set high for subsequent counting and overflows and you must detect these overflows by comparing the present count to previous counts.

Constructing the Answer

Construct the answer "Final" with the following procedure:

1. Check for overflow by checking that bit 7 of the first byte is high. Bits 0 through 6 of the first byte are always 0 for counting functions since results are 32 bits maximum (bytes 2, 3, 4, and 5 = mantissa; byte 6 = exponent). Therefore, the byte is 80_{16} if bit 7 is high, 00_{16} if there is no overflow. If the bit is set, the data is invalid unless the function is totalize or one of the count functions.

First data word A(1): (part of mantissa)

BIT NUMBER															
15	14	13	12	11	10	9	8	7	6	5	4	3	2	1	0
Bits 15 - 8 are ignored								**	data bits#						

** = overflow bit

= For counting functions, these bits are always 0; when the result is hertz or seconds, these bits provide valid data for constructing the answer.

Second through fifth data words A(2) - A(5): (part of mantissa)

BIT NUMBER															
15	14	13	12	11	10	9	8	7	6	5	4	3	2	1	0
Bits 15 - 8 are ignored								data bits#							

Some counting functions are a 16-bit count while others are a 32-bit count. See the following list:

- If the function is modulo counting, the second and third bytes (bits 0-7) indicate the number of times the present count has overflowed (bits 0-7 of the 4th and 5th words = 16-bit count).
- If the function is gated counting, the 2nd and 3rd bytes (bits 0-7) are always zero (bits 0-7 of the 4th and 5th words = 16-bit count).
- All other counting functions give a 32-bit count (bits 0-7 of the 2nd, 3rd, 4th, and 5th words = 32 bits).

Sixth data word A(6): (exponent)

BIT NUMBER															
15	14	13	12	11	10	9	8	7	6	5	4	3	2	1	0
Bits 15 - 8 are ignored								data bits							

2. Binary AND the first byte A(1) with 127 (masks bits 7 and above) and each remaining byte with 255 [masks bits 8 and above].
3. Final = $(A(1)*2^{32} + A(2)*2^{24} + A(3)*2^{16} + A(4)*2^8 + A(5)) * 2^{(A(6)-128)}$

The exponent has the value $2^{(A(6) - 128)}$.

Register Programming Flowchart

This section provides a flowchart of the process used to make a measurement with a command that returns data and pulls the interrupt after completing the measurement. The flowchart shows how to execute the command and then retrieve the data.

Make Measurement

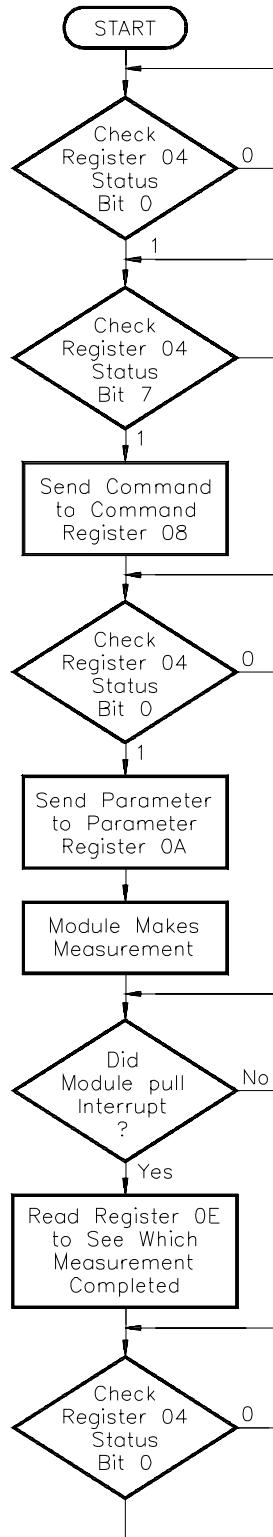

Read Data

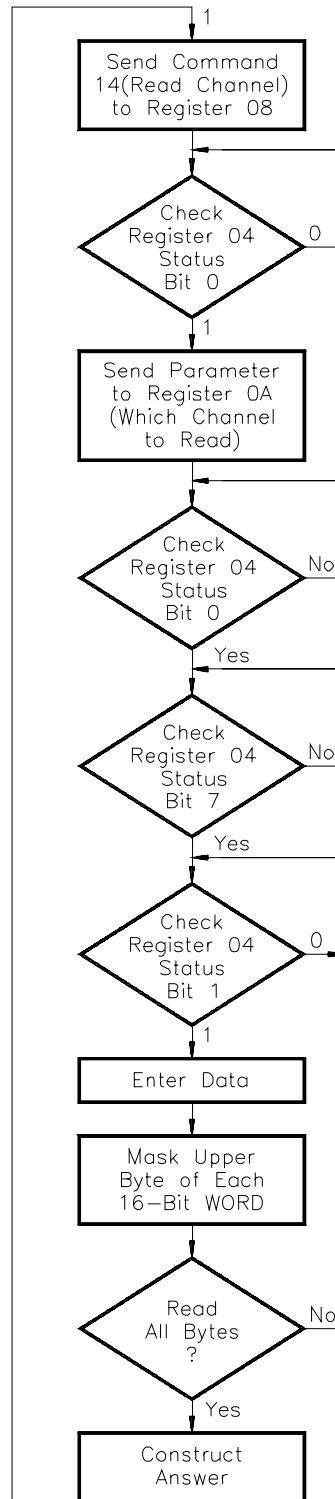

Embedded Controller Example Programs

This section shows example programs for the Agilent E1480A V/360 embedded Model 360-based VXI controller. These programs make a frequency measurement on channel 1 using the programming procedure previously discussed. Two programming versions are provided: one written in BASIC/UX and another written in C programming language.

System Configuration	Mainframe:	Agilent 75000 Series C (Agilent E1400B)
	Controller:	Agilent V/360 (Agilent E1480A) w/Resource Manager and Slot 0
	Programming Language:	BASIC/UX, C
	Counter/Totalizer:	Agilent E1332A (Logical address = 48)

```
BASIC/UX Version  10    !Compute the base address of the E1332A at a logical address of 48.
                   20    Logical_address=48
                   30    Base_address=(Logical_address*64)+49152
                   40    !Map the A16 address space for READIO/WRITEIO calls on the V/360.
                   50    CONTROL 16,25;2
                   60    COM Base_address
                   70    !Reset the counter.
                   80    CALL Reset_counter
                   90    !Call the interrupt service routine when an interrupt occurs.
                  100    ON INTR 16 GOSUB Int_service
                  110    !Enable VME interrupts on the Agilent V/360.
                  120    ENABLE INTR 16;2
                  130    !Set the function and gate time (Frequency and gate time = 1024 msec).
                  140    CALL Send_cmd(4,9)
                  150    !Computer can perform other tasks until interrupt occurs.
                  160    FOR I=1 TO 5000
                  170    DISP I
                  180    NEXT
                  190    STOP                !Stop if interrupt has not occurred yet.
                  200    !The interrupt service routing performs two tasks:
                  210    ! 1. Ensure the device interrupting has logical address 48 (Agilent
                  E1332A).
                  220    ! 2. Ensure status returned indicates Agilent E1332A frequency complete
                  230    !on channel one.
                  240    Int_service:STATUS 16,4;Stat4    !V/360 interrupt reason.
                  250    STATUS 16,6;Stat6    !VXI device interrupt acknowledge value.
                  260    IF Stat4<>2 THEN STOP
                  270    Intr_address=BINAND(Stat6,255)
                  280    IF Intr_address<>Logical_address THEN
                  290    PRINT "Expected counter logical address 48 to interrupt"
                  300    STOP
                  310    END IF
                  320    Status_register=BINAND(BINAND(SHIFT(Stat6,8),255),255)
```

```

330     IF Status_register<>239 THEN
340     PRINT "Expected status register to contain 000000EF HEX"
350     PRINT " Received a status register:";
360     PRINT DVAL$(Status_register,16);"HEX"
370     STOP
380     END IF
390     !

400     !Call the subprogram to read, convert and print out the result.
410     CALL Read_data
420     !
430     END

440     !This subprogram reads the Status Register of the device and returns
450     !the operational status bits.
460     SUB Read_status(Status,Rdy,Done,Qryrdy)
470     Read_status: !
480         COM Base_address
490         Status=READIO(-16,Base_address+4)
500         Rdy=BIT(Status,0)
510         Done=BIT(Status,7) AND Rdy
520         Qryrdy=BIT(Status,1)
530     SUBEND

540     !This subprogram calls Read_status subprogram to check status bit 0
550     !(RDY) to determine when a command or parameter can be sent.
560     SUB Wait_not_bsy
570         COM Base_address
580         REPEAT
590         CALL Read_status(Status,Rdy,Done,Qryrdy)
600         UNTIL Rdy
610     SUBEND

620     !This subprogram calls Read_status to check the validity of status bit 7
630     !(DONE). This ensures the validity of status bit 1.
640     SUB Wait_done
650         COM Base_address
660         REPEAT
670         CALL Read_status(Status,Rdy,Done,Qryrdy)
680         UNTIL Done
690     SUBEND

700     !This subprogram call Read_status to check status bit 1 to determine
710     !when the Response Register contains data.
720     SUB Qry_ready
730         COM Base_address
740         REPEAT
750         CALL Read_status(Status,Rdy,Done,Qryrdy)
760         UNTIL Qryrdy
770     SUBEND

780     !This subprogram resets the counter using command 15.
790     SUB Reset_counter
800         COM Base_address
810         WRITEIO -16,Base_address+8;15
820         CALL Wait_not_bsy
830         WRITEIO -16,Base_address+10;0
840         WAIT 1
850     SUBEND

```

```

860 !This subprogram writes commands and parameters to the Command
870 !and Parameter Registers. The state of the Agilent E1332A is
checked
880 !before either write to prevent sending commands/parameters before
890 !the device is ready for them.
900 SUB Send_cmd(Cmd,Parm)
910     COM Base_address
920     CALL Wait_not_bsy
930     WRITEIO -16,Base_address+8;Cmd
940     CALL Wait_not_bsy
950     WRITEIO -16,Base_address+10;Parm
960 SUBEND

970 !This subroutine retrieves the data, converts it and prints out the
980 !reading.
990 SUB Read_data
1000     COM Base_address
1010     INTEGER A(6)
1020     CALL Send_cmd(14,0)
1030     CALL Wait_done
1040     FOR I=1 TO 6
1050     CALL Qry_ready
1060     A(I)=READIO(-16,Base_address+8)
1070     A(I)=BINAND(A(I),255)
1080     NEXT I

1090     !Check for overflow.
1100     IF BIT(A(1),7)=1 THEN
1110     PRINT "OVERFLOW OCCURRED - DATA INVALID"
1120     END IF
1130     A(1)=BINAND(A(1),127)
1140     M=(A(1)*2^32+A(2)*2^24+A(3)*2^16+A(4)*2^8+A(5))*2^(A(6)-128)
1150     PRINT "MEASURED FREQUENCY:",M,"Hz."
1160 SUBEND

```

C Version

```

/*****
 * C Program for frequency measurements using Agilent E1332A Counter *
 *****/
#include <stdio.h>
#include <fcntl.h>
#include "sys/vxi.h"      /*source file for Agilent V/360 VXI drivers*/
#define logical_address48 /*Logical Address of Agilent E1332A*/

/*Initialize interrupt flag*/
int i_flag =0;
typedef unsigned short word;
typedef struct device_registers {
    word id_register;
    word devtype_register;
    word statuscontrol_register;
    word reserved_register;
    word cmdresponse_register;
    word parameter_register;
    word reserved2_register;
    word ivector_register;
}DEVICE_REGISTERS;

/*Function to reset the Agilent E1332A counter*/
void reset_dac32A(d32A_ptr)
DEVICE_REGISTERS *d32A_ptr;
{
    int l;

    /*send reset command 15 to command register*/
    d32A_ptr->cmdresponse_register=15;

    /*wait for READY bit to become valid*/
    while(((d32A_ptr->statuscontrol_register)&1)==0);

    /*send parameter to begin reset activity*/
    d32A_ptr->parameter_register=0;

    /*Wait a few microseconds to allow reset activity to complete*/
    for (l=0;l<100;l++) {}
}

/*Function to send commands and parameter to Agilent E1332A counter*/
void dac32A_send(d32A_ptr,command,parameter)
DEVICE_REGISTERS *d32A_ptr;
int command, parameter;
{
    /*wait for READY bit to become valid*/
    while(((d32A_ptr->statuscontrol_register)&1)==0);

    /*send the command to the Command Register*/
    d32A_ptr->cmdresponse_register=command;

    /*wait for the READY bit to become valid*/
    while(((d32A_ptr->statuscontrol_register)&1)==0);

    /*send the parameter to the Parameter Register*/
    d32A_ptr->parameter_register=parameter;
}

```

```

/*Function to retrieve and convert the counter reading*/
float d32A_read(d32A_ptr,command,channel)
DEVICE_REGISTERS *d32A_ptr;
{
float result, r_exp = 1;
int k;
unsigned short data_word;

/*wait for DONE, QUERY RESPONSE and READY bits to become valid*/
while(((d32A_ptr->statuscontrol_register)&0x83)!=0x83);

/*get the first byte of data*/
data_word = ((d32A_ptr->cmdresponse_register)&0xff);

/*check for overflow*/
if ((data_word &1) == 1)
{
printf("\n\nOVERFLOW OCCURRED - DATA INVALID\n");
exit(0);
}

/*place first byte in the result variable*/
result = data_word << 32;

/*wait for QUERY RESPONSE REGISTER READY bit to become valid*/
while(((d32A_ptr->statuscontrol_register)&2)==0);

/*get second byte of data*/
data_word = ((d32A_ptr->cmdresponse_register)&0xff);
result = result + (data_word << 24);

/*wait for QUERY RESPONSE REGISTER READY bit to become valid*/
while(((d32A_ptr->statuscontrol_register)&2)==0);

/*get third byte of data*/
data_word = ((d32A_ptr->cmdresponse_register)&0xff);
result = result +(data_word << 16);

/*wait for QUERY RESPONSE REGISTER READY bit to become valid*/
while(((d32A_ptr->statuscontrol_register)&2)==0);

/*get fourth byte of data*/
data_word = ((d32A_ptr->cmdresponse_register)&0xff);
result = result + (data_word << 8);

/*wait for QUERY RESPONSE REGISTER READY bit to become valid*/
while(((d32A_ptr->statuscontrol_register)&2)==0);

/*get fifth byte of data*/
data_word = ((d32A_ptr->cmdresponse_register)&0xff);
result = result + data_word;

/*wait for QUERY RESPONSE REGISTER READY bit to become valid*/
while(((d32A_ptr->statuscontrol_register)&2)==0);

/*get sixth byte of data*/
data_word = ((d32A_ptr->cmdresponse_register)&0xff);

```

```

/*convert sixth byte, the exponent*/
for (k=data_word-128; k<0; k++)
{
    r_exp = r_exp/2;
}
result = result * r_exp;
return result;
}

/*Interrupt handler routine*/
int handler(eid,causevec)
int eid;
struct interrupt_struct *causevec;
{
    /*set the interrupt flag to alert main program that counter has reading*/
    i_flag=1;

    /*ensure the correct interrupt has occurred*/
    if ((causevec->mask&0xffff) != 0xef30)
    {
        printf("\n\nReceived incorrect interrupt vector\n");
        printf("Expected interrupt from E1332A at logical address 48\n");
        printf("\n Received interrupt vector: %x HEX\n",causevec->mask&0xffff);
        printf("    Expecting: ef30 HEX \n");
        printf("    ef HEX --> channel one frequency complete\n");
        printf("    30 HEX --> logical address of 48\n");
        exit(0);
    }
}

main()
{
    int eid;
    DEVICE_REGISTERS *dev;
    int i;
    struct interrupt_struct causevec;
    float reading;

    /*Open the Agilent V/360 VXI interface*/
    eid=open("/dev/vxi/primary",O_RDWR);
    if(eid){
        perror("open");
        exit(1);
    }

    /*Mask for VME interrupts*/
    causevec.cause = 0x2;

    /*Set up interrupt handler for interrupting device*/
    io_on_interrupt(eid,&causevec,handler);

    /*Enable interrupts on the VXI interface*/
    io_interrupt_ctl(eid,1);

    /*Retrieve the pointer for the A16 registers of the device*/
    dev=(DEVICE_REGISTERS *)vxi_get_a16_addr(eid,logical_address);

    /*Call the function to reset the counter*/
    reset_dac32A(dev);
}

```

```

/*Set the function: Frequency with 1024 msec gate time*/
dac32A_send(dev,4,9);

/*Let computer perform some other task while waiting for interrupt*/
for (i=0;i<3500;i++)
{
printf("\r%i",i);
/*check interrupt flag and if set, end looping*/
if (i_flag ==1)
{ i=4000; }
}

/*Send the command to read the result*/
dac32A_send(dev,14,0);

/*Call the function to retrieve and convert the reading*/
reading = d32A_read(dev,14,0);

/*Print out the measured frequency*/
printf("\nFrequency is %.1f \n",reading);
}

```

Register Programmed Pulse Width

The Agilent E1332A can do two Pulse Width measurements at the same time, however; the restriction (when programmed via SCPI) is that both measurements must be started at the same time and that no data is received until both have completed. These restrictions do not exist when register programming is used. This BASIC language program has been written to run on an external computer connected via GPIB to the E1300B/E1301B. All programming of the Agilent E1332A Counter, including handling interrupts, is handled by the system instrument in the E1300B/E1301B. The following provides a standard starting point from which to begin an application.

- MAIN
The MAIN line code 10-190 provides a error handling shell
- E13xx_errors
Checks for any errors in all instruments

To do rapid debugging you need to be able to see program flow, program variables, and instrument errors. A good ERROR and TIME OUT handling shell is an essential part of this.

The main lines of this program (lines 10-190) act as a shell that prevents your BASIC program from hanging due to I/O that is not proceeding. They will identify the LINE NUMBER of lines that have RUN TIME ERRORS or that have TIMED OUT. Then the shell will call the subprogram E13xx_errors which will query instruments for errors. Often timeouts are caused by doing an ENTER after having sent incorrect commands to instruments. Since the Shell prevents I/O deadlocks, BASIC's PAUSE, STEP, and CONT can now be used to debug programs. When a program doesn't seem to be proceeding correctly, use PAUSE and then STEP to trace the flow; type variable names to see their value when PAUSED; and finally use CONT to proceed at full speed. In order

for this shell to catch errors and time outs, all application code must start in the Subprogram Main.

The previous register programming example for BASIC/UX of the Agilent E1332A was used as the starting point for this example. The following subprograms are taken directly from this example, and one modified to use the system instrument to register program.

- Read_status
- Wait_not_bsy
- Wait_done
- Qry_ready
- Reset_counter
- Send_cmd
- Read_data

The following subprograms were added to support the pulse width problem.

Subprogram	Function
Start_pw2	Starts a pulse width measurement on channel 1-2.
Start_pw4	Starts a pulse width measurement on channels 3-4.
Whos_done	Returns a zero true value to indicate completion of a measurement for each channel.
Read_ivr	Reads the interrupt vector register used by Whos_done.
Read_pw2	Reads the completed measurement on channel 1-2.
Read_pw4	Reads the completed measurement on channel 3-4.
Status_dump	Returns the full register status for debugging.

The following subprograms were added to show how to handle interrupts.

- Main
Initializes the counter and sets up for interrupts
- Intr_req
Provides on going servicing of counter interrupts

The two IRQ jumpers on the E1332 have been moved from the normal IRQ1 position to the IRQ2 position. **You must move both of them.** This is necessary so that the system instrument can separate interrupts intended for this program from interrupts generated from all other register based SCPI drivers. Once these jumpers are moved and the command to the system instrument of DIAG:INT:SETUP2 ON has been issued, then only register programming is possible until the command to the system instrument of DIAG:INT:SETUP2 OFF has been issued. The pulse width function uses pairs of channels 1-2 and 2-4. The Subprograms "Read_pw2" and "Read_pw4" handle the condition when you program channels 2 or 4, but read data from channels 1 and 3.

This program was tested using the built-in pacer of the E1300B/01B as a source of a signal. Output from the program follows the end of the program.

```
10 !Re-save "COUNT_PW2" .
20 !This main line code is reserved as a error handling shell.
30 !All application code must be at lower level context.
40 ASSIGN @Sys TO 70900 !Define I/O paths.
50 ASSIGN @Counter TO 70906
60 COM /Instr/ @Sys,@Counter
70 COM /Register/ Logical_address

75 !Turn TIMEOUTS to errors--this branch never taken.
80 ON TIMEOUT 7,3 GOTO End

90 !This handles timeouts and errors not handled at lower level contexts
100 ON ERROR RECOVER Kaboom

110 Main !Put application code in this sub.
120 PRINT "Checking for E13xx Errors at the end of the program"
130 E13xx_errors
140 GOTO End
150 Kaboom:PRINT ""
160 PRINT ERRM$
170 PRINT "Checking for E13xx Errors as a BASIC Error has occurred"
180 E13xx_errors
190 End:END

200 !This sub reads all errors from E13xx instruments.
210 SUB E13xx_errors
220 COM /Instr/ @Sys,@Counter
230 DIM A$[128]
240 ABORT 7 !Free bus handshakes.
250 CLEAR @Sys !Clear instrument activity & clear I/O buffers.
260 REPEAT
270 OUTPUT @Sys;"SYST:ERR?"
280 ENTER @Sys;A,A$
290 PRINT "SYSTEM ERROR ";A$
300 UNTIL A=0
310 SUBEND

320 !This subroutine is treated as the main line.
330 SUB Main
340 Main: !
350 COM /Instr/ @Sys,@Counter
360 COM /Register/ Logical_address
370 !Put application code here.
380 !Generate a input signal with the pacer.
390 CLEAR @Sys
400 OUTPUT @Sys;"*RST;*CLS;*OPC?"
410 ENTER @Sys;A

415 !Setup a signal source using the pacer
420 OUTPUT @Sys;"SOUR:PULS:COUNT INF;;SOUR:PULS:PER .004;:INIT"

425 !Counters logical address.
430 Logical_address=48

435 !Reset the counter.
440 CALL Reset_counter
450 !
```

```

460 !Now setup the system instrument to catch backplane
465 !interrupt on IRQ2.
470 OUTPUT @Sys;"STATUS:OPER:ENAB 256;*SRE 128"
475 !SRQ on backplane int.
480 OUTPUT @Sys;"DIAG:INT:SETUP2 ON"
485 !System instrument to catch IRQ2.
490 OUTPUT @Sys;"DIAG:INT:ACT ON;*OPC?"
500 ENTER @Sys;A
510 PRINT "FINISHED SYS SETUP"
520 ON INTR 7,2 CALL Intr_req
525 !Start pulse width on channel 2.
530 CALL Start_pw2
535 !Start pulse width on channel 4.
540 CALL Start_pw4
550 ENABLE INTR 7;2
560 !This is just a wait loop.
570 LOOP
580 PRINT TIMEDATE
590 END LOOP
595 !Check the register level status.
600 CALL Status_dump
610 SUBEND
620 !
630 SUB Read_status(Status,Rdy,Done,Qryrdy)
640 Read_status: !
650 COM /Register/ Logical_address
660 COM /Instr/ @Sys,@Counter
670 OUTPUT @Sys;"VXI:READ? "&VAL$(Logical_address)&","4"
680 ENTER @Sys;Status
690 Rdy=BIT(Status,0)
700 Done=BIT(Status,7) AND Rdy
710 Qryrdy=BIT(Status,1)
720 SUBEND
730 SUB Wait_not_bsy
740 COM /Register/ Logical_address
750 REPEAT
760 CALL Read_status(Status,Rdy,Done,Qryrdy)
770 UNTIL Rdy
780 SUBEND
790 SUB Wait_done
800 COM /Register/ Logical_address
810 REPEAT
820 CALL Read_status(Status,Rdy,Done,Qryrdy)
830 UNTIL Done
840 SUBEND
850 SUB Qry_ready
860 COM /Register/ Logical_address
870 REPEAT
880 CALL Read_status(Status,Rdy,Done,Qryrdy)
890 UNTIL Qryrdy
900 SUBEND 1

```

```

910 SUB Reset_counter
920   COM /Register/ Logical_address
930   COM /Instr/ @Sys,@Counter
940   OUTPUT @Sys;"VXI:WRITE "&VAL$(Logical_address)&",&8,15"
950   CALL Wait_not_bsy
960   OUTPUT @Sys;"VXI:WRITE "&VAL$(Logical_address)&",&10,0"
970 SUBEND

980 SUB Send_cmd(Cmd,Parm)
990   COM /Register/ Logical_address
1000  CALL Wait_not_bsy
1010  COM /Instr/ @Sys,@Counter
1020  OUTPUT @Sys;"VXI:WRITE "&VAL$(Logical_address)&",&8,&VAL$(Cmd)
1030  CALL Wait_bit_bsy
1040  OUTPUT @Sys;"VXI:WRITE "&VAL$(Logical_address)&",&10,&VAL$(Parm)
1050 SUBEND

1060 SUB Read_data(Result,Ch)
1070   COM /Instr/ @Sys,@Counter
1080   COM /Register/ Logical_address
1090   INTEGER A(6)
1100   CALL Send_cmd(14,Ch)
1110   CALL Wait_done
1120   FOR I=1 TO 6
1130     CALL Qry_ready
1140     OUTPUT @Sys;"VXI:READ? "&VAL$(Logical_address)&",&8"
1150     ENTER @Sys;A(I)
1160     A(I)=BINAND(A(I),255)
1170   NEXT I

1180   !Check for overflow.
1190   IF BIT(A(1),7)=1 THEN
1200     PRINT "OVERFLOW OCCURRED - DATA INVALID"
1210   END IF
1220   A(1)=BINAND(A(1),127)
1230   Result=(A(1)*2^32+A(2)*2^24+A(3)*2^16+ A(4)*2^8+A(5))*2^(A(6)-128)
1240 SUBEND

1250 SUB Status_dump
1260   COM /Instr/ @Sys,@Counter
1270   COM /Register/ Logical_address
1280   PRINT "IN STATUS_DUMP"
1290   CALL Whos_done(Pw2,Pw4)
1300   PRINT "PW2 ";Pw2;" PW4 ";Pw4
1310   CALL Read_pw2(Data)
1320   PRINT "PW2 ";Data
1330   CALL Read_pw4(Data)
1340   PRINT "Pw4 ";(Data)
1350   FOR Parm=0 TO 7
1360     CALL Send_cmd(13,Parm)
1370     CALL Wait_done
1380     CALL Qry_ready
1390     OUTPUT @Sys;"VXI:READ? "&VAL$(Logical_address)&",&8"
1400     ENTER @Sys;Query
1410     Query=BINAND(Query,255)
1420     PRINT "Status ";Parm;Query;DVAL$(Query,2)
1430   NEXT Parm
1440 SUBEND

```

```

1450 SUB Read_ivr(Ivr)
1460 Read_ivr: !
1470 COM /Register/ Logical_address
1480 COM /Instr/ @Sys,@Counter
1490 OUTPUT @Sys;"VXI:READ? "&VAL$(Logical_address)&","14"
1500 ENTER @Sys;Ivr
1510 PRINT "interrupt vector";Ivr;DVAL$(Ivr,2)
1520 SUBEND

1530 SUB Start_pw2
1540 CALL Send_cmd(1,153) !Set input level = .5V=153=(2.56+.5)/.020
1550 CALL Send_cmd(7,2) !Pulse width channel 2 ppw.
1560 SUBEND

1570 SUB Start_pw4
1580 CALL Send_cmd(2,170) !Set input level =.5V=153=(2.56+.5)/.020
1590 CALL Send_cmd(7,3) !Pulse width channel 4 ppw.
1600 SUBEND

1610 SUB Whos_done(Pw2,Pw4)
1620 CALL Read_ivr(Ivr)
1630 Pw2=BIT(Ivr,14)
1640 Pw4=BIT(Ivr,15)
1650 SUBEND

1660 SUB Read_pw2(Data)
1670 CALL Read_data(Data,0) !Read channel 2 ppw.
1680 SUBEND

1690 SUB Read_pw4(Data)
1700 CALL Read_data(Data,2) !Read channel 4 ppw.
1710 SUBEND

1720 SUB Intr_req
1730 COM /Instr/ @Sys,@Counter
1740 PRINT "got a interrupt"
1750 OUTPUT @Sys;"DIAG:INT:RESP?"
1760 ENTER @Sys;Int_ack !Must enter Interrupt Acknowledge query.
1770 PRINT "INTERRUPT ACKNOWLEDGE ";Int_ack;DVAL
      $(Int_ack,2);" = LADD ";BINAND(Int_ack,255)
1780 A=SPOLL(@Sys) !Must serial poll to clear status byte.
1790 PRINT "SERIAL POLL VALUE ";A
1800 OUTPUT @Sys;"STAT:OPER:EVEN?"
1810 ENTER @Sys;Stat_oper
1820 PRINT "STATUS:OPERATION:EVENT ";Stat_oper
1830 CALL Whos_done(Pw2,Pw4)
1840 IF Pw2=0 THEN !A zero means a reading is ready.
1850 CALL Read_pw2(Data)
1860 PRINT "Pulse width on channel 2 = ";Data
1870 ELSE
1880 END IF
1890 IF Pw4=0 THEN !A zero means a reading is ready.
1900 CALL Read_pw4(Data)
1910 PRINT "Pulse width on channel 4 = ";Data
1920 ELSE
1930 END IF

1940 !Now do another round of counter inputs.
1950 IF Pw2=0 THEN CALL Start_pw2
1960 IF Pw4=0 THEN CALL Start_pw4
1970 OUTPUT @Sys;"DIAG:INT:SETUP2 ON;:DIAG:INT:ACT ON;*OPC?"

```

```
1980  ENTER @Sys;A
1990  ENABLE INTR 7;2
2000  SUBEND
```

Program Output FINISHED SYS SETUP got a interrupt

```
INTERRUPT ACKNOWLEDGE -16592
1111111111111111011111100110000 = LADD 48
```

```
SERIAL POLL VALUE 192
```

```
STATUS:OPERATION:EVENT 256
```

```
interrupt vector 16383 0000000000000000011111111111111
```

```
Pulse width on channel 2 =.00199999660254
```

```
Pulse width on channel 4 =.00200019776821 got a interrupt
```

```
INTERRUPT ACKNOWLEDGE 16176
0000000000000000011111100110000 = LADD 48
```

```
SERIAL POLL VALUE 192
```

```
STATUS:OPERATION:EVENT 256
```

```
interrupt vector 16383 0000000000000000011111111111111
```

```
Pulse width on channel 2 =.00199999660254
```

```
Pulse width on channel 4 =.00199999660254
```

Appendix C

Agilent E1332A Counter/Totalizer Error Messages

Table C-1 lists the error messages associated with the Agilent E1332A 4-Channel Counter/Totalizer module programmed by SCPI. See the appropriate mainframe or command module manual for a complete list of error messages.

Table C-1. 4-Channel Counter/Totalizer Error Messages

Number	Title	Potential Cause(s)
-211	Trigger ignored	Trigger occurred while the instrument is in the idle state, trigger occurred from another source not specified, or trigger too fast.
-214	Trigger deadlock	Attempt to start a measurement (with MEAS? or READ?) which cannot complete because of the current TRIGger:SOURce setting.
-221	Settings conflict	General error indicating that the command could not be executed because of a conflict with another setting. Attempted to INITiate a measurement on a channel with the function set to "UNDEFINED".
-222	Data out of range	A parameter value is to large or too small.
-230	Data corrupt or stale	Data retrieved from memory is possibly invalid.
-231	Data questionable	Measurement cannot be made to the requested resolution. Measurement data is possibly invalid. The value returned was the best the Counter/Totalizer could perform.
-240	Hardware error	Hardware error detected during power-on cycle.
-314	Save/recall memory lost	Configuration retrieved from specified location in memory invalid or missing. A valid save must be performed at the specified location before retrieving data.
-330	Self-test failure	Error detected during self-test.
2001	Invalid channel number	The channel specified is not allowed to execute the command.

- *CLS, 104, 107, 110
- *ESE, 101, 107
- *ESE?, 107
- *ESR?, 107
- *IDN?, 107, 110
- *OPC, 107
- *OPC?, 107, 110
- *RCL, 107, 110
- *RST, 22, 42, 107, 110
- *SAV, 107, 110
- *SRE, 107
- *SRE?, 107
- *STB, 101
- *STB?, 107, 110
- *TRG, 23, 107, 110
- *TST?, 107, 110
- *WAI, 107

A

- A16 Address Space, 115
- Abbreviated Commands, 64
- ABORt Command, 50, 67
- About Register-Based Programming, 113
- Address
 - base, 115
 - logical, 16
 - registers, 113 - 114
 - secondary GPIB, 14
 - space (A16), 115
 - switch, 16
- Addressing Registers, 116
- Aperture Time
 - channel selection, 95
 - description, 52
 - frequency measurement, 95
 - query, 95
 - selecting, 51, 95
 - setting, 52
 - versus resolution, 52, 95

B

- Base Address, 115
- Bit Number to Decimal Value, 101
- Block Diagram, 12
- Boolean Command Parameters, 65

C

- Cables, shielded, 19
- Cautions, 15
- Certification, 5
- Channel
 - connections, 13
 - descriptions, 13
 - event detection controls, 45
 - event level, 93
 - implied, 64
 - input selection jumper, 18
 - isolated input characteristics, 13
 - isolated input terminal, 13
 - measurement functions, 11
 - monitoring, 77 - 78
 - non-isolated input characteristics, 13
 - non-isolated input terminal, 13
- Checking
 - for errors, 57, 104
 - for overflow, 58, 132
- *CLS, 104, 107, 110
- Command Parameter Register, 120
- Command Reference, 63 - 110
- Command/Response Register, 119
- Commands
 - abbreviated, 64
 - IEEE 488.2, 63, 107, 110
 - implied, 64
 - implied channel, 64
 - keyword, 64
 - linking, 66
 - optional, 64
 - optional parameters, 65
 - parameters, 65
 - parsing, 113

C (continued)

Commands (continued)

- query parameters, 65
- quick reference, 108 - 110
- SCPI format, 63
- separator, 64
- summary (register-based), 122 - 129
- types, 63

Common (*) Commands, 63

- *CLS, 104, 107, 110
- *ESE, 101, 107
- *ESE?, 107
- *ESR?, 107
- format, 63
- *IDN?, 107, 110
- list of, 107
- *OPC, 107
- *OPC?, 107, 110
- parameters, 63
- quick reference, 110
- *RCL, 107, 110
- *RST, 22, 42, 107, 110
- *SAV, 107, 110
- *SRE, 107
- *SRE?, 107
- *STB, 101
- *STB?, 107, 110
- *TRG, 23, 107, 110
- *TST?, 107, 110
- *WAI, 107

Condition Register, 102

CONFigure Subsystem, 48, 68 - 75

CONFigure:FREQuency, 69

CONFigure:NWIDth, 70

CONFigure:PERiod, 71

CONFigure:PWIDth, 72

CONFigure:TINTerval, 73

CONFigure:TOTALize, 74

CONFigure:UDCount, 75

CONFigure? Command, 76

Configuring the Counter/Totalizer, 15 - 20, 41

Conformity, declaration, 7

Connecting Field Wiring, 19

Constraints, input signal, 24

Control Register, 117

Counter/Totalizer

- command reference, 63 - 110

- command summary, 122 - 129

- configuring the, 15 - 20, 41

- default conditions, 22

- description, 11

- error numbers/messages, 149

- getting started, 11 - 14

- parameter summary, 122 - 129

- programming, 14

- query SCPI commands, 61

- register-based programming, 113 - 148

- specifications, 111 - 112

- synchronizing with a computer, 60

- understanding the, 41 - 62

- using the, 21 - 40

Counting Function, 29 - 30

Cut-off Frequency, 81

D

Decimal Value of Bit Numbers, 101

Declaration of Conformity, 7

Default Conditions, 22

Definition of Instrument, 14

Description, 11

Device Type Register, 117

Digital Low-pass Filter, 44

- cut-off frequency, 44

- enable/disable, 83

- query frequency, 82

- query state, 83

- setting frequency, 81 - 82

Discrete Command Parameters, 65

DISPlay Subsystem, 77 - 78

DISPlay:MONitor:CHANnel, 77

DISPlay:MONitor:CHANnel?, 77

DISPlay:MONitor[:STATe], 78

DISPlay:MONitor[:STATe]?, 78

Documentation History, 6

Down Counting, 29 - 30

E

Embedded Controller Example Programs, 135 - 141

Enable Register, 103

Error

checking for, 57

detecting, 57

messages, 149

numbers, 149

quantizing, 82

query for, 104

queue, 104

*ESE, 101, 107

*ESE?, 107

*ESR?, 107

Event Level, 45

channel 1 & 2, 122

channel 3 & 4, 122

channel selection, 93

description, 45

jumpers, 93

output format, 93

query, 93

setting, 45, 93, 122

Event Register, 102 - 103

Event Slope, 45

channel selection, 94

description, 45

measurements using, 94

query polarity, 94

setting, 45, 94

F

FETCh? Command, 49 - 50, 79

Field Wiring, 19

Filter

enable/disable, 83

frequency, 81 - 82

query state of, 82 - 83

Format

common commands, 63

SCPI commands, 63

Frequency

cut-off, 81

digital low-pass filter, 44, 81 - 82

low-pass filter, 44

Frequency Measurement, 31 - 33

aperture time, 95

channel selection, 69

configuring for, 69

overflow indication, 69, 86

Frequency Measurement (*continued*)

performing, 86

range, 69, 86

resolution, 70, 87

G

Gate Time, 52, 95

Gated Totalize

channel selection, 99

enable/disable, 100

measurement, 27 - 28, 99

overflow indication, 99

polarity, 99

polarity, setting, 54

query polarity, 99

query state, 100

selecting, 54

state, setting, 54

Getting Started, 11 - 14

GPIB

group execute trigger (GET), 23, 55 - 56, 105

secondary address, 14

Group Execute Trigger, 23, 55 - 56, 105

I

*IDN?, 107, 110

IEEE 488.2 Commands

See Common (*) Commands

Implied

channel, 64

commands, 64

INITiate Command, 49, 80

Input

frequency measurement, 31 - 32

gated totalize measurement, 27 - 28

low-pass filter, 44, 81 - 83

maximum voltage/power allowed, 13 - 15, 24

non-isolated level, 18

non-isolated pull-up resistor, 18

parallel frequency measurement, 33

parameters, selecting, 44

period measurement, 34 - 35

pulse width measurement, 36 - 37

selection jumper, 18

signal conditioning, 44

signal constraints, 24

terminal blocks, 19

terminal selection, 24

I (continued)

Input (continued)

- terminals, 13, 24, 44, 84
- time interval measurement, 38 - 39
- totalize measurement, 25 - 26
- up/down count measurement, 29 - 30
- INPut Subsystem, 81 - 84
- INPut:FILTer[:LPASs]:FREQuency, 81
- INPut:FILTer[:LPASs]:FREQuency?, 82
- INPut:FILTer[:LPASs][:STATE], 83
- INPut:FILTer[:LPASs][:STATE]?, 83
- INPut:ISOLate, 84
- INPut:ISOLate?, 84
- Instrument Definition, 14
- Interrupt
 - acknowledge line (IACK*), 121
 - checking for overflow using, 59
 - handler, 121
 - lines, 17
 - modulo count, 126
 - priority, 17
 - register-based programming, 17
 - requests, 121
 - vector register, 120
- IRQ Jumpers, 17, 121
- Isolated
 - channel input terminal, 13
 - input characteristics, 13
 - input terminal, 24, 44, 84
 - period measurement, 34 - 35

J

Jumpers

- event level, 93
- input selection, 18
- interrupt priority, 17
- IRQ, 17, 121

K

Keywords

- description, 14
- rules for use, 64

L

- LADDR, 16
- Linking Commands, 66
- Logical Address, 16
- Low-pass Filter
 - description, 44
 - digital, 44, 81 - 83
 - enable/disable, 83
 - frequency, 44, 81 - 82
 - setting, 44

M

- Manufacturer ID Register, 117
- MEASure Subsystem, 48, 85 - 90
- MEASure:FREQuency?, 86
- MEASure:NWIDth?, 87
- MEASure:PERiod?, 88
- MEASure:PWIDth?, 89
- MEASure:TINTerval?, 90
- Measurement
 - channel functions, 11
 - contact closure, 18
 - frequency, 31 - 33
 - functions, 46, 96
 - gated totalizing, 27 - 28, 54, 99
 - initiating, 80, 91
 - parallel, 23
 - period average, 34 - 35, 71, 88
 - procedure, 43
 - pulse width, 36 - 37, 141 - 147
 - range, 50
 - ranges, 13
 - resolution, 50
 - retrieve from memory, 79
 - SCPI commands, 47
 - sequential, 23
 - specifications, 111 - 112
 - stopping, 50
 - time interval, 38 - 39, 73, 90
 - totalizing, 25 - 26, 74
 - up/down count, 29 - 30, 75
 - using event slope, 94
- Modulo Count, 126
- Multiple SCPI Commands, linking, 66

N

Negative Pulse Width

- channel selection, 70, 87
- configuring for, 70
- edge select, 70, 87
- overflow indication, 70, 87
- performing measurement, 87
- range, 70, 87
- resolution, 70, 87

Non-isolated

- channel input terminal, 13
- frequency measurement, 31 - 32
- gated totalize measurement, 27 - 28
- input characteristics, 13
- input level, 18
- input pull-up resistor, 18
- input terminal, 24, 44
- parallel frequency measurement, 33
- pulse width measurement, 36 - 37
- time interval measurement, 38 - 39
- totalize measurement, 25 - 26
- up/down count measurement, 29 - 30

Number of Periods

- description, 53
- selecting, 51
- setting, 53
- versus resolution, 53, 98

Numeric Command Parameters, 65

O

*OPC, 107

*OPC?, 107, 110

Optional

- command parameters, 65
- commands, 64

Overflow

- checking for, 58 - 59, 132
- detecting, 57

P

Parallel Measurements, 23

Parameters

- register, 120
- SCPI commands, 65
- selecting for input, 44
- summary (register-based), 122 - 129

Parsing Commands, 113

Period Average Measurement, 34 - 35

- channel selection, 71, 88, 98
- configuring for, 71
- enter number of periods, 98
- overflow indication, 71, 88
- performing, 88
- range, 71, 88
- resolution, 71, 88
- selecting number of periods, 98
- signals measured, 71, 88

Polling, 57

Positive Pulse Width

- channel selection, 72, 89
- configuring for, 72
- edge select, 72, 89
- overflow indication, 72, 89
- performing measurement, 89
- range, 72, 89
- resolution, 72, 89

Power-on State, 22

Program Examples

- BASIC/UX, 135 - 137, 143 - 147
- C version, 138 - 141
- embedded controller, 135 - 141
- frequency measurement, 31 - 32
- gated totalize measurement, 27
- period measurement, 34
- pulse width measurement, 36
- register programmed pulse width, 143 - 147
- time interval measurement, 38
- totalize measurement, 25
- up/down count measurement, 29

Programming

- procedure, 130 - 133
- register-based, 113 - 148
- the counter/totalizer, 14

Pull-up Resistor, 18

Pulse Width Measurement, 36 - 37

- negative, 70, 87
- positive, 72, 89
- register programmed, 141 - 147

Q

Query

- aperture time, 95
- command parameters, 65
- errors, 104
- event level, 93
- event slope polarity, 94
- filter frequency, 82
- filter state, 83
- gate channel polarity, 99
- input terminal state, 84
- measurement function, 97
- monitor mode channel, 77
- monitor mode state, 78
- number of periods, 98
- response register, 119
- SCPI commands, 61
- totalized measurements, 100
- trigger source, 106

Questionable Data/Signal Register, 101

Quick Reference

- IEEE 488.2 common commands, 110
- SCPI commands, 108 - 110

R

Range

- description, 50
- selecting, 50
- setting, 51, 68

*RCL, 107, 110

READ Registers, 116

- device type, 117
- interrupt vector, 120
- manufacturer ID, 117
- response, 119
- status, 117

READ? Command, 49, 91

Register-Based Programming, 113 - 148

- base address, 115
- command summary, 122 - 129
- computing the answer, 132 - 133
- description, 113
- example programs, 135 - 141, 143 - 147
- flowchart, 134
- interrupt requests, 121
- parameter summary, 122 - 129
- pulse width, 141 - 147
- register definitions, 116
- register descriptions, 117

Register-Based Programming (*continued*)

- register offset, 116
- register programming procedure, 130 - 133

Registers

- addressable, 116
- addressing, 113 - 114, 116
- base address, 115
- command parameter, 120
- command/response, 119
- condition, 102
- control/status, 117
- definitions, 116
- descriptions, 117
- device type, 117
- enable, 103
- event, 102 - 103
- interrupt vector, 120
- manufacturer ID, 117
- offset, 116
- parameter, 120
- programming procedure, 130 - 133
- query response, 119
- questionable data/signal, 101
- READ, 116
- response/command, 119
- standard event status, 101
- standard operational status, 101
- status byte, 101
- status/control, 117
- WRITE, 116

Reset

- default conditions, 22, 42
- state, 22

Resistor, non-isolated input pull-up, 18

Resolution

- description, 50
- selecting, 50
- setting, 51, 68
- versus aperture time, 52, 95
- versus number of periods, 53, 98

Response/Command Register, 119

*RST, 22, 42, 107, 110

S

- Safety Warnings, 6, 15
- *SAV, 107, 110
- Schematic, simplified, 12
- SCPI Commands, 63
 - abbreviated, 64
 - ABORt, 50, 67
 - CONFigure subsystem, 48, 68 - 75
 - CONFigure?, 76
 - default, 42
 - DISPlay subsystem, 77 - 78
 - FETCh?, 49 - 50, 79
 - format used, 63
 - implied, 64
 - INITiate, 49, 80
 - INPut subsystem, 81 - 84
 - keyword description, 14
 - linking, 66
 - long form, 64
 - MEASure subsystem, 48, 85 - 90
 - optional, 64
 - optional parameters, 65
 - parameters, 65
 - query parameters, 65
 - querying the counter/totalizer, 61
 - quick reference, 108 - 110
 - READ?, 49, 91
 - reference, 66
 - selecting, 14
 - [SENSe:] subsystem, 92 - 100
 - short form, 64
 - STATus subsystem, 101 - 103
 - SYSTem subsystem, 104
 - TRIGger subsystem, 105 - 106
- Selecting
 - aperture time, 51, 95
 - gated totalize, 54
 - input parameters, 44
 - non-isolated input level, 18
 - non-isolated input pull-up resistor, 18
 - number of periods, 51
 - range, 50
 - resolution, 50
 - SCPI commands, 14
 - trigger source, 54
- [SENSe:] Subsystem, 92 - 100
- [SENSe:]EVENT:LEVel, 93
- [SENSe:]EVENT:LEVel?, 93
- [SENSe:]EVENT:SLOPe, 94
- [SENSe:]EVENT:SLOPe?, 94
- [SENSe:]FREQuency:APERture, 95
- [SENSe:]FREQuency:APERture?, 95
- [SENSe:]FUNCTion, 48, 96
 - :FREQuency, 96
 - :NWIDTH, 96
 - :PERiod, 96
 - :PWIDth, 96
 - :TINTerval, 96
 - :TOTAlize, 96
 - :UDCount, 96
- [SENSe:]FUNCTion?, 97
- [SENSe:]PERiod:NPERiods, 98
- [SENSe:]PERiod:NPERiods?, 98
- [SENSe:]TOTAlize:GATE, 99
 - :POLarity, 99
 - :POLarity?, 99
 - [:STATe], 100
 - [:STATe]?, 100
- Sequential Measurements, 23
- Setting
 - aperture time, 52
 - event level, 45, 93, 122
 - event slope, 45, 94
 - gated totalize polarity, 54
 - gated totalize state, 54
 - input low-pass filter, 44
 - input signal conditioning, 44
 - logical address, 16
 - number of periods, 53
 - range, 51, 68
 - resolution, 51, 68
- Shielded Cables, 19
- Signal
 - conditioning controls, 44
 - constraints, 24
- Specifications, 111 - 112
- Speed, increasing measurement cycle, 51
- *SRE, 107
- *SRE?, 107
- Standard Commands for Programmable Instruments
 - See* SCPI Commands
- Standard Event Status Register, 57, 101
- Standard Operational Status Register, 101
- Static Electricity, 15
- Status Byte Register, 101
- STATus Subsystem, 101 - 103
- Status/Control Register, 117
- STATus:QUEStionable, 102
- STATus:QUEStionable:CONDition?, 102
- STATus:QUEStionable:ENABle, 102
- STATus:QUEStionable:ENABle?, 103
- STATus:QUEStionable[:EVENT]?, 103
- *STB, 101
- *STB?, 107, 110

S (continued)

Stopping a Measurement, 50
Synchronizing
 instruments, 60
 the counter/totalizer, 60
SYSTem Subsystem, 104
SYSTem:ERRor?, 104

T

Table of Contents, 1 - 4
Terminal
 blocks (input), 19
 input selection, 24, 44
 isolated input, 84
Time Interval Measurement, 38 - 39
 channel selection, 73, 90
 configuring for, 73
 overflow indication, 73, 90
 performing, 90
 range, 73, 90
 resolution, 73, 90
 start and stop edges, 73, 90
Totalizing Measurement, 25 - 26
 channel selection, 74
 configuring for, 74
 gated, 27 - 28, 54, 99
 overflow indication, 74
 reading measurement results, 74
 resolution, 74
 timing, 74
*TRG, 23, 107, 110
Trigger Source
 SCPI commands, 55, 105 - 106
 selecting, 54
TRIGger Subsystem, 105 - 106
Trigger System Commands, 106
TRIGger[:IMMediate], 56, 105
TRIGger:SOURce, 55, 105
 BUS, 55, 105
 HOLD, 56, 105
 IMMediate, 56, 105
TRIGger:SOURce?, 106
*TST?, 107, 110

U

Understanding the Counter/Totalizer, 41 - 62
Up/Down Counting, 29 - 30
 channel selection, 75
 configuring for, 75
 range, 75
 reading measurement results, 75
 resolution, 75
 timing, 75
Using the Counter/Totalizer, 21 - 40

V

Voltage, maximum allowed, 13 - 15, 24
VXIbus Backplane Interrupt Lines, 17

W

*WAI, 107
WARNINGS, 6, 15
Warranty, 5
Wire, maximum gage, 19
Wiring
 connecting, 19
 guidelines, 19
WRITE Registers, 116
 command, 119
 command parameter, 120
 control, 117